

6663

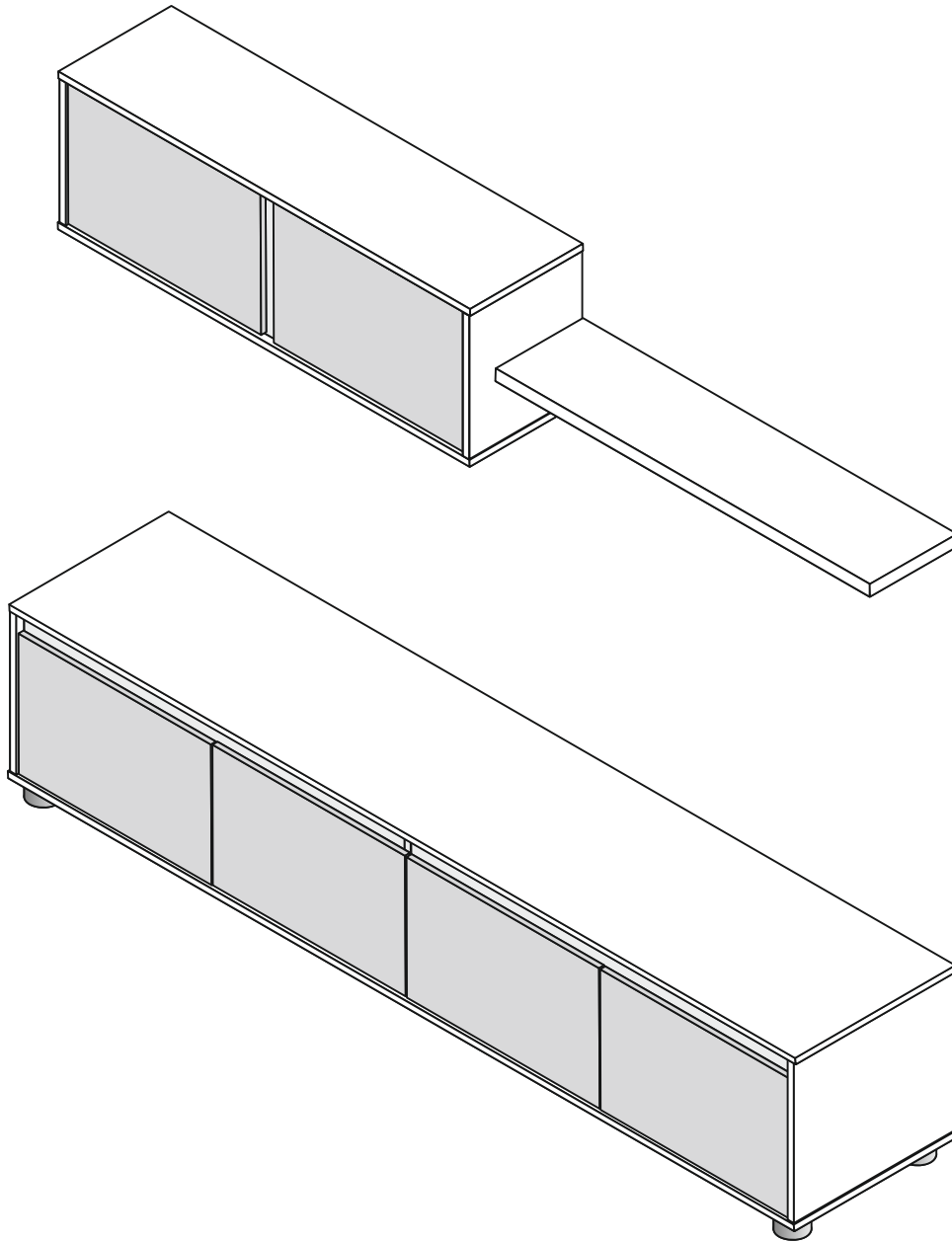

**SALÓN TV - TV LIVING ROOM - SÉJOUR TV - MÓVEL PARA SALA -
TV SOGGIORNO - FERNSEHRAUM - ΈΠΙΠΛΑ ΓΙΑ ΤΟ ΣΑΛΟΝΙ**

**INSTRUCCIONES DE MONTAJE - ASSEMBLING INSTRUCTIONS - NOTICE DE MONTAGE- INSTRUÇÕES DE MONTAGEM -
ISTRUZIONI DI MONTAGGIO - MONTAGEANLEITUNG - ΟΔΗΓΙΕΣ ΣΥΝΑΡΜΟΛΟΓΗΣΗΣ**

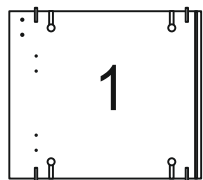
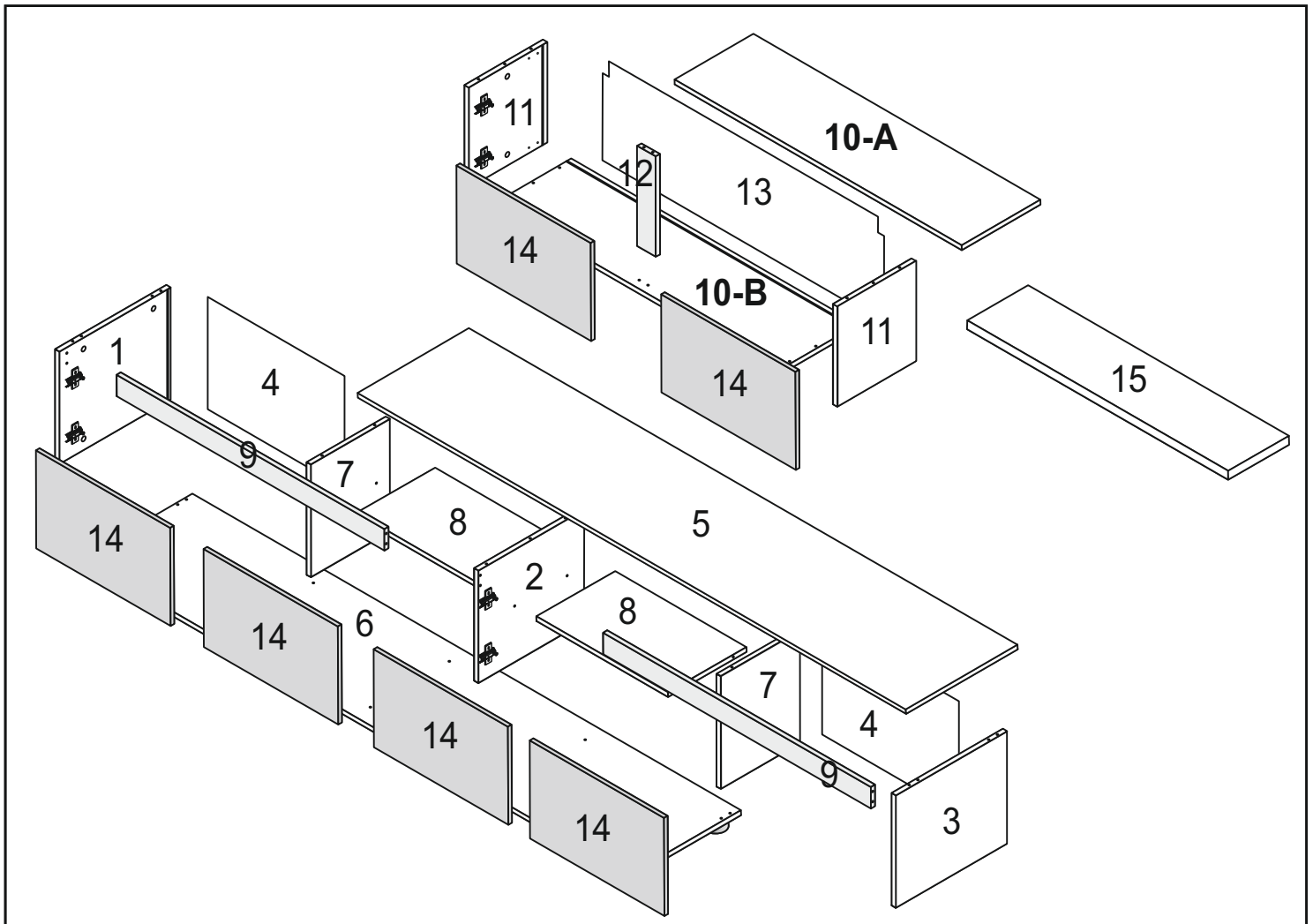

355 x 406 mm

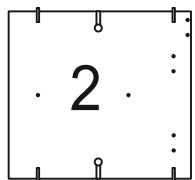

355 x 386 mm

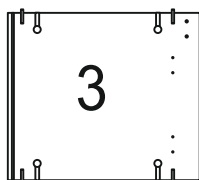

355 x 406 mm



500 x 355 mm

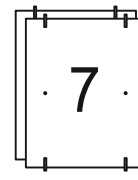

355 x 288 mm

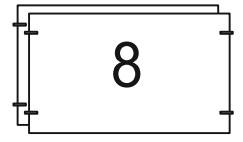

480 x 287 mm



2000 x 407 mm



317 x 68 mm

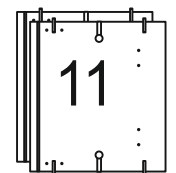

317 x 287 mm

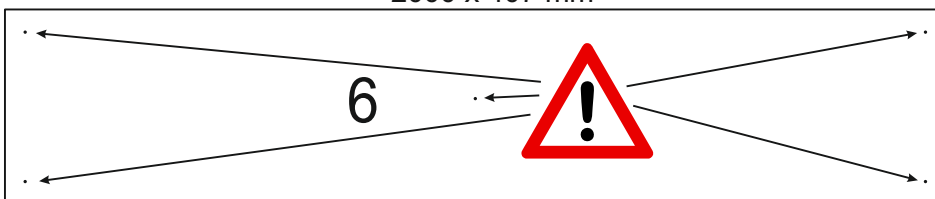

2000 x 407 mm



976 x 68 mm



1027 x 326 mm

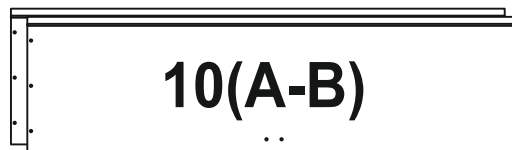

10(A-B)

1048 x 288 mm



15

953 x 208 mm

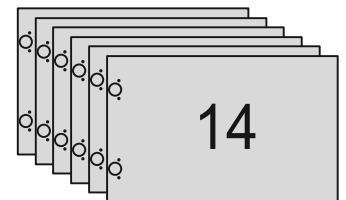

490 x 310 mm

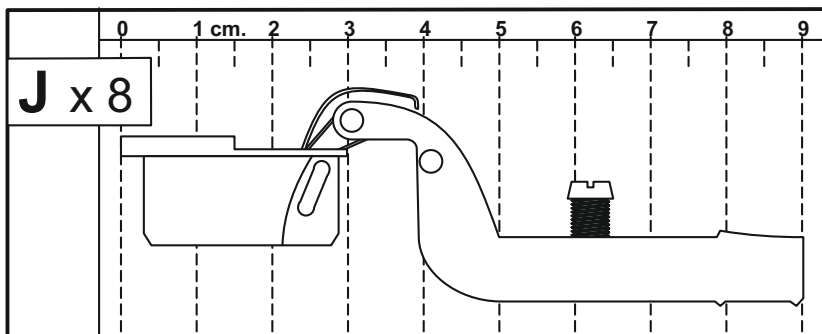
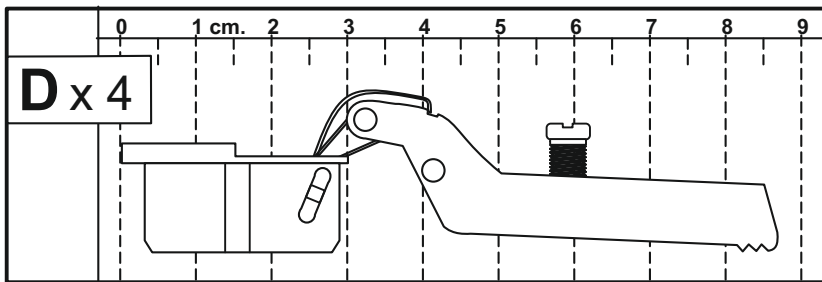
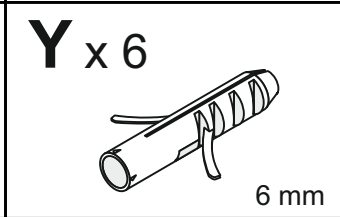
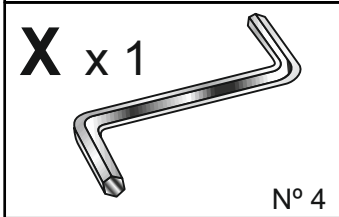
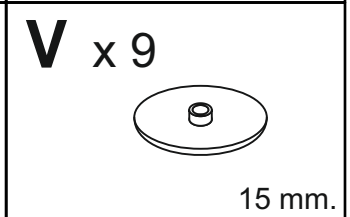
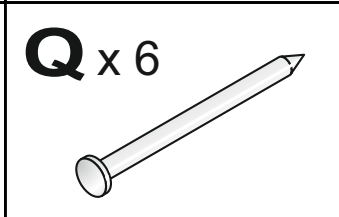
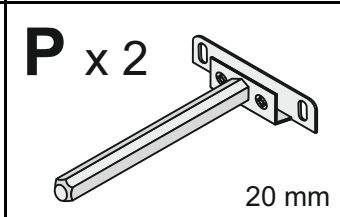
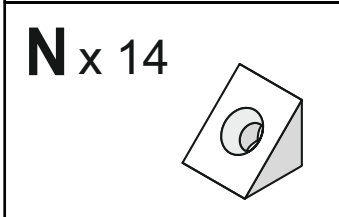
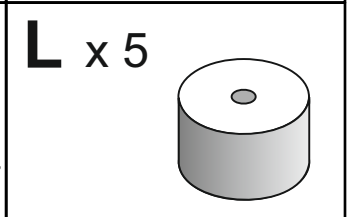
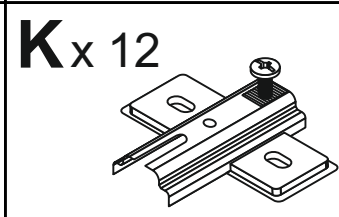
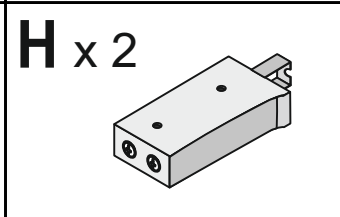
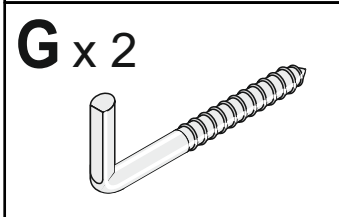
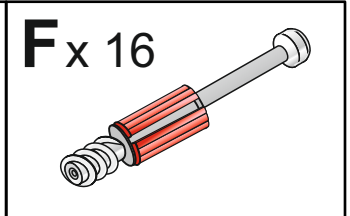
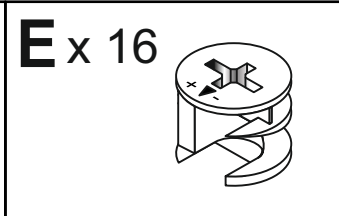
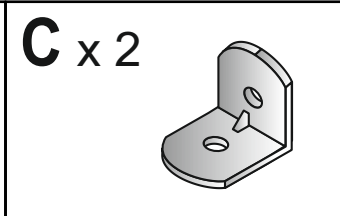
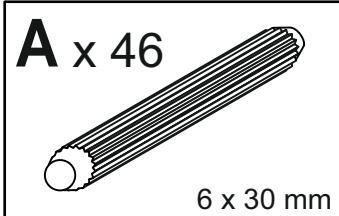
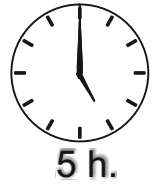
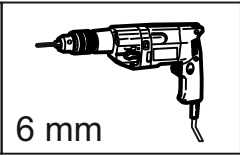
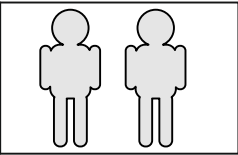
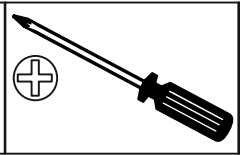
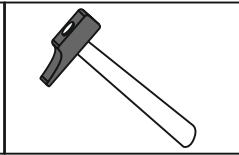
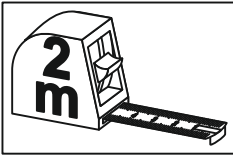

	0	1 cm.	2	3	4
	R x 14				
					3.5 x 20 mm
	S x 9				
					4 x 30 mm
	T x 44				
					4 x 16 mm
	W x 4				
					4.5 x 45 mm
	Z x 8				
					M6 x 9 mm

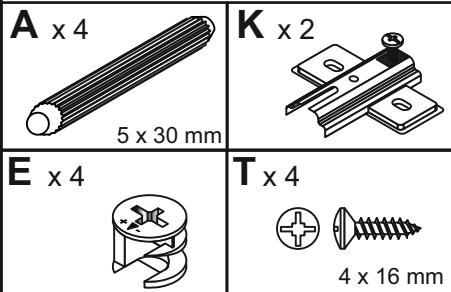
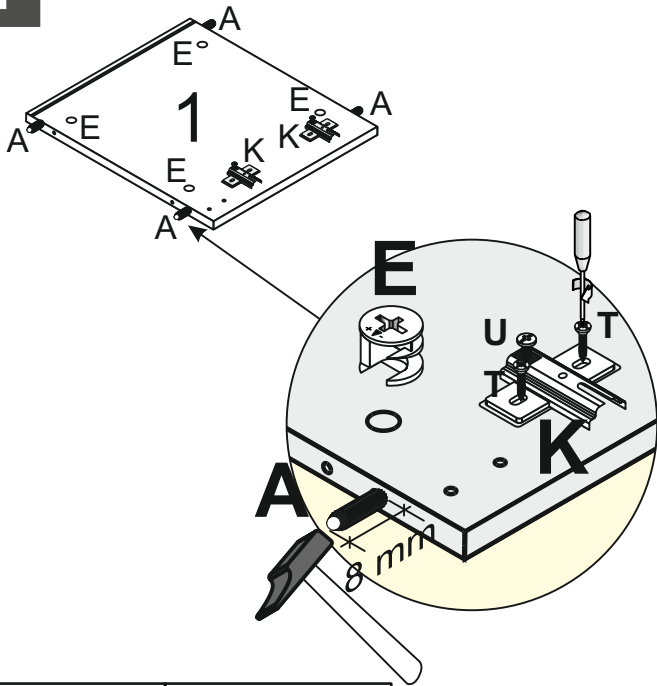
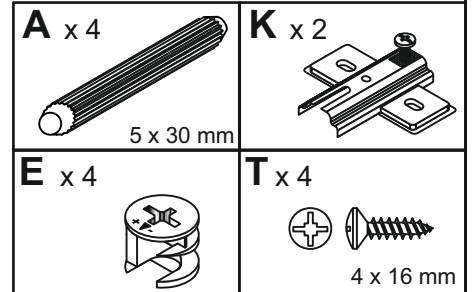
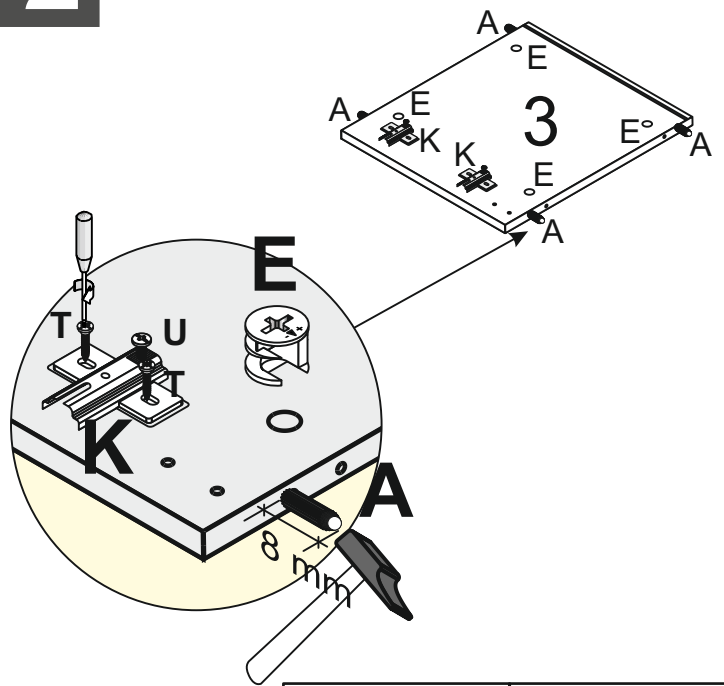
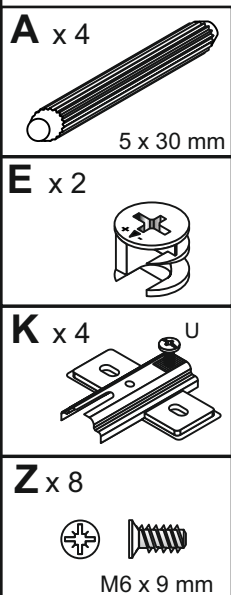
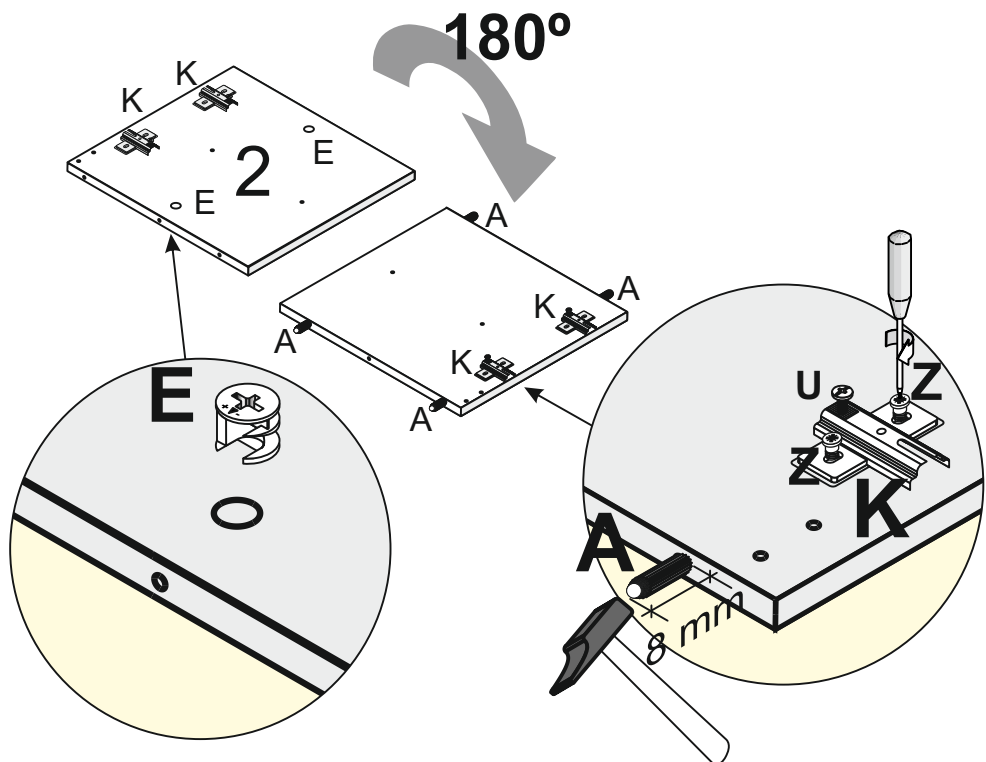
1**2****3**

4

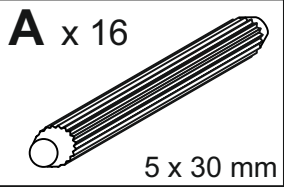
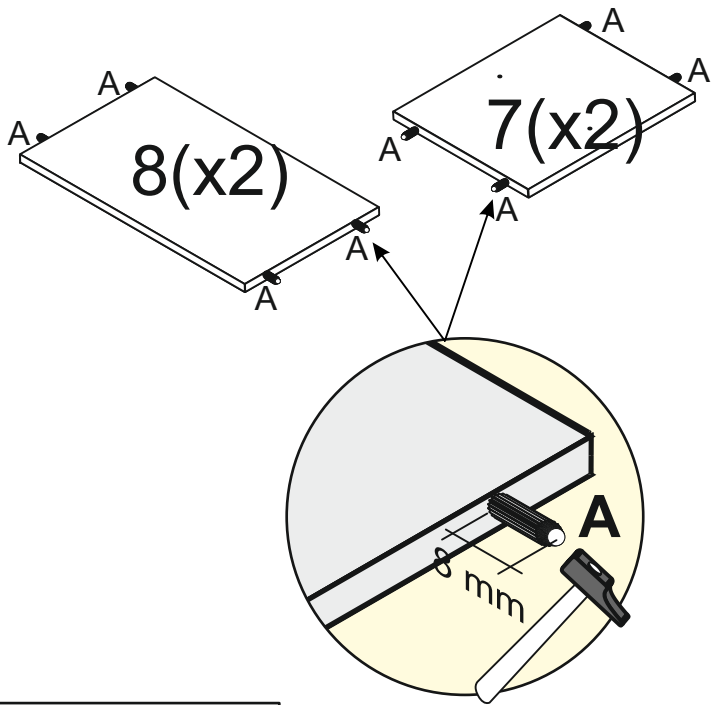

5

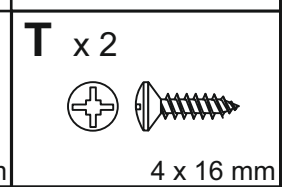
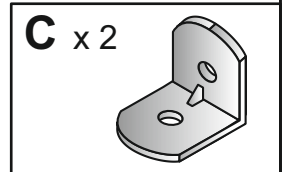
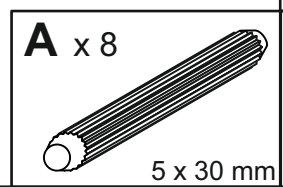
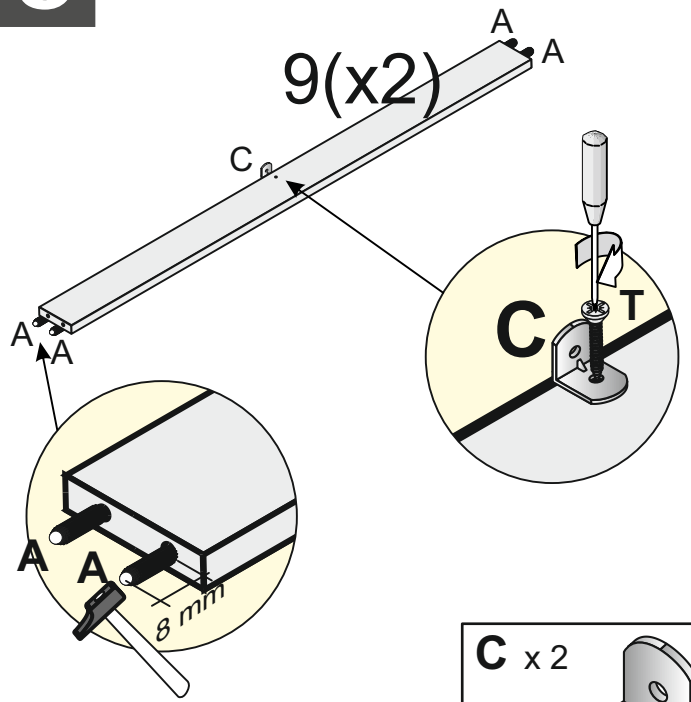

6

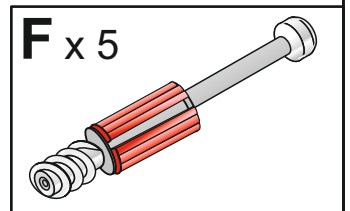
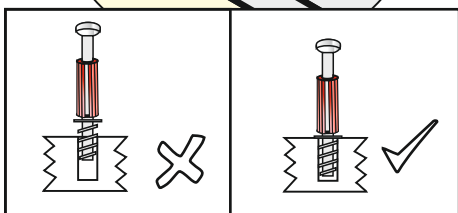
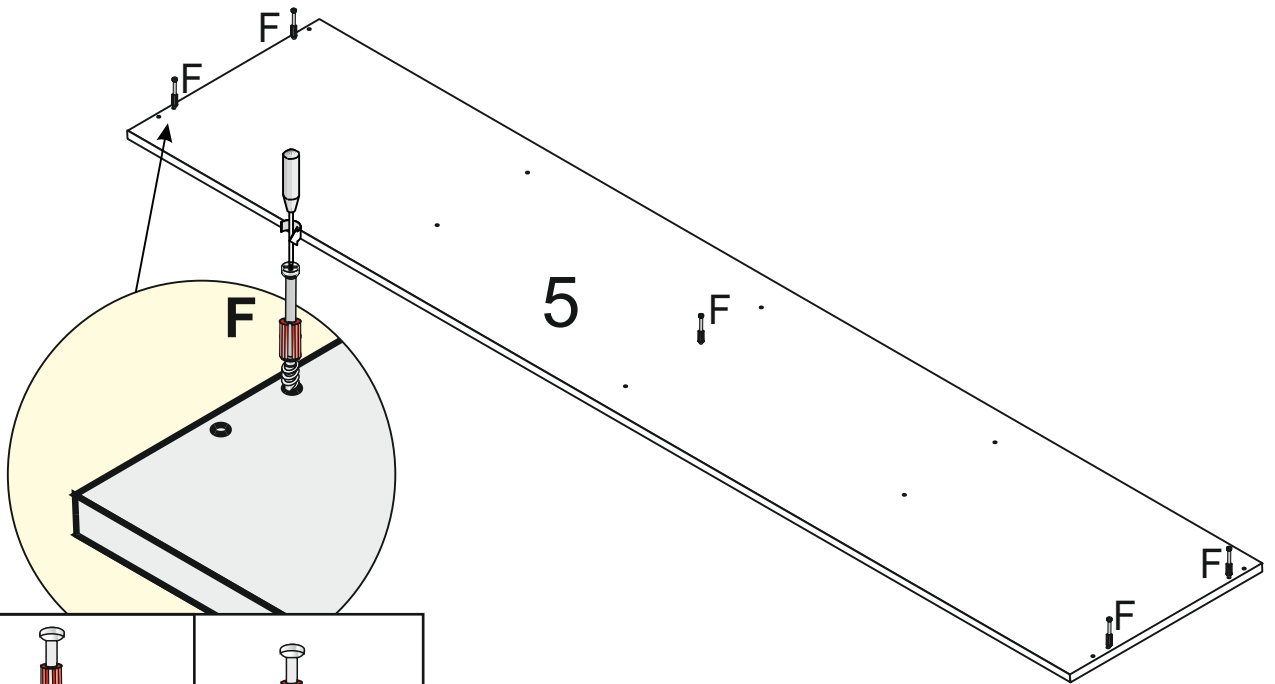

7

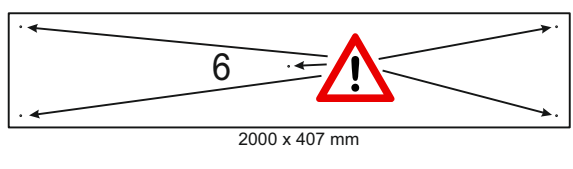
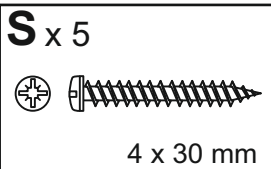
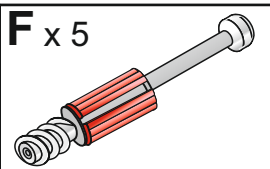
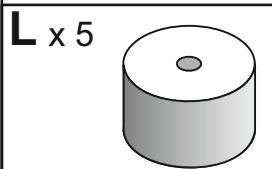
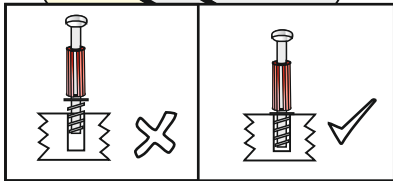
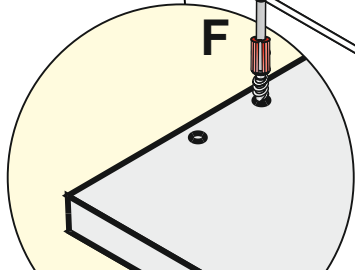
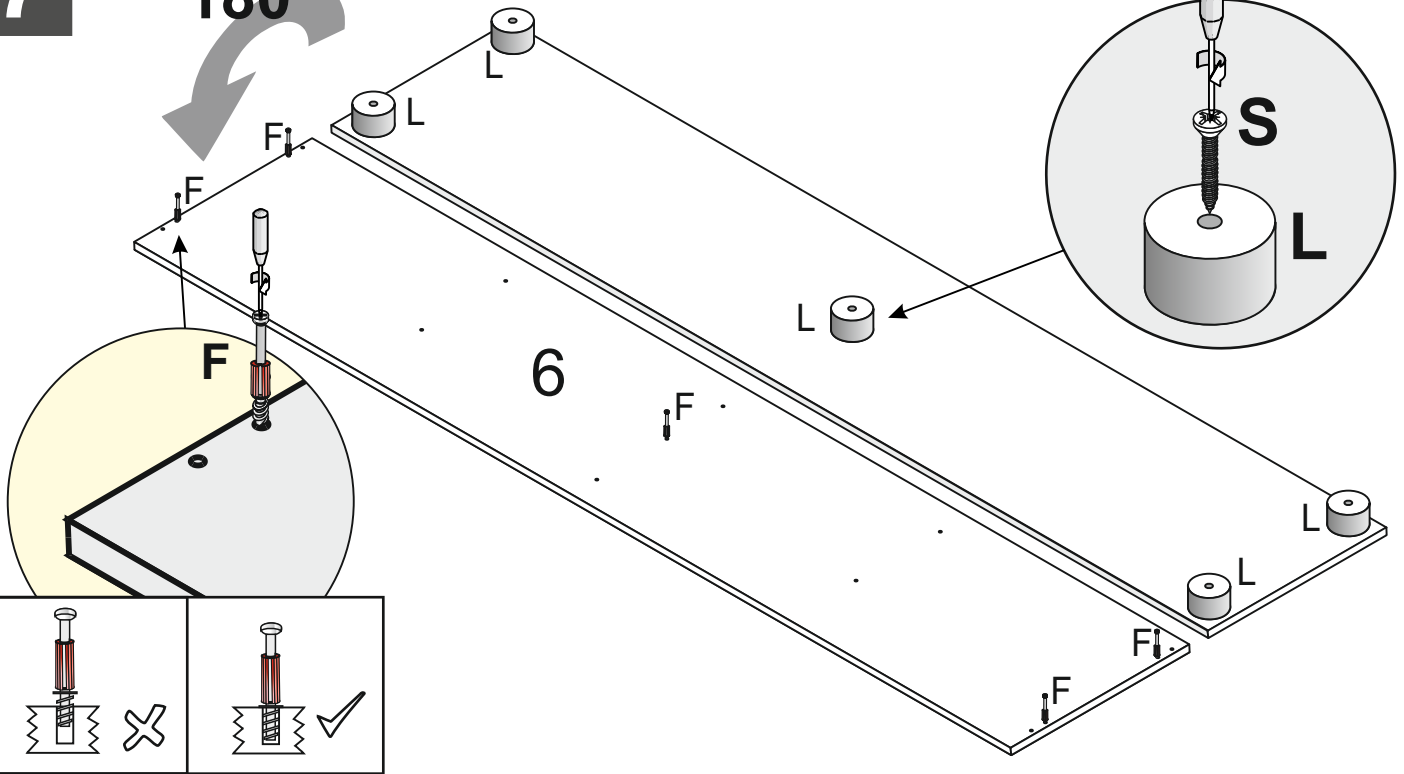
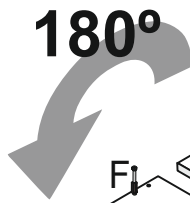

8

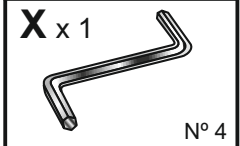
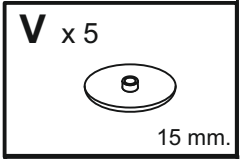
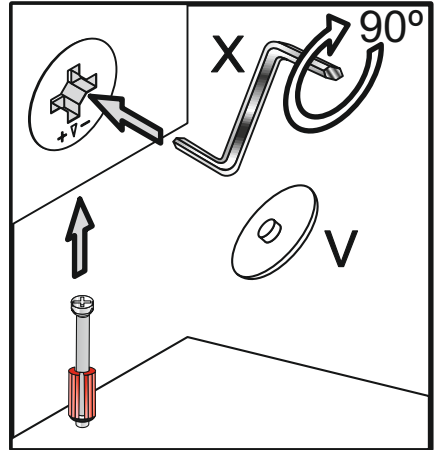
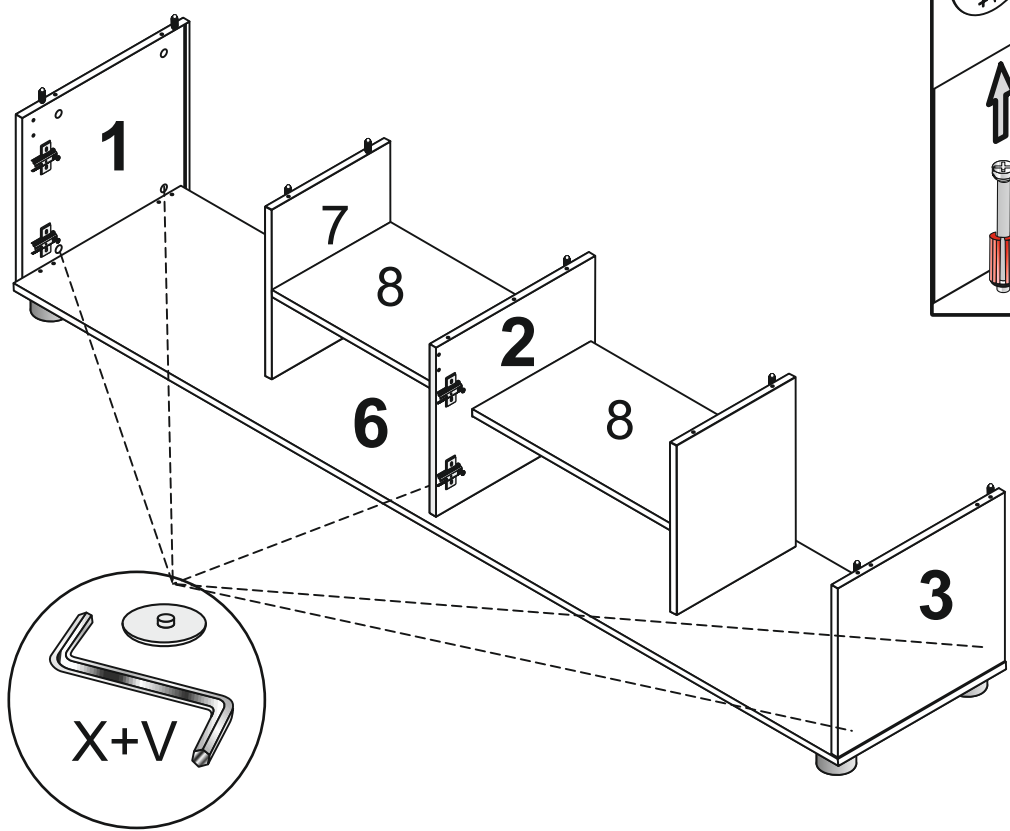

9

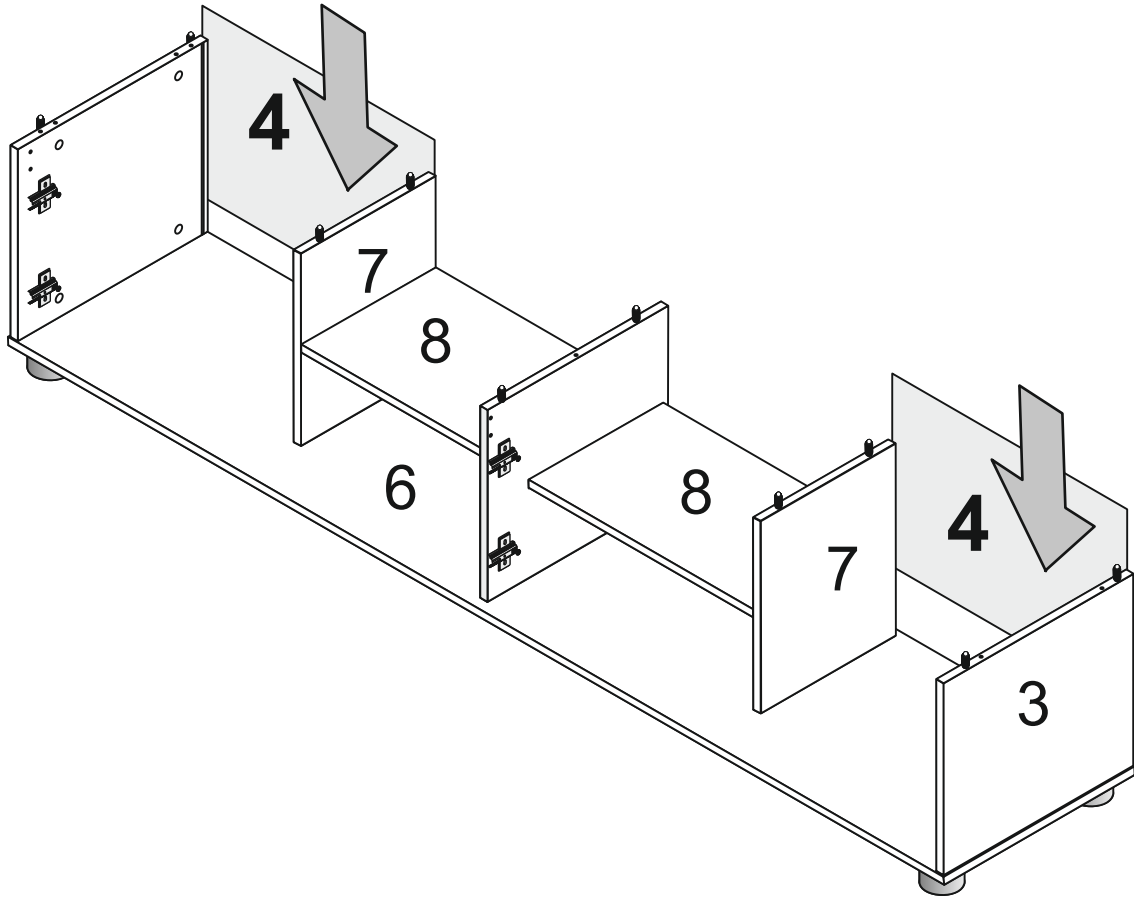

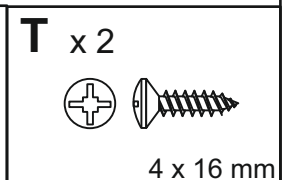
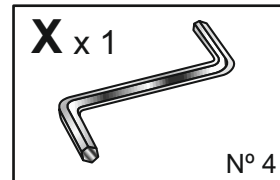
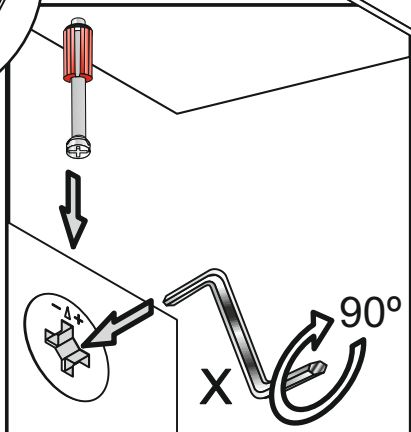
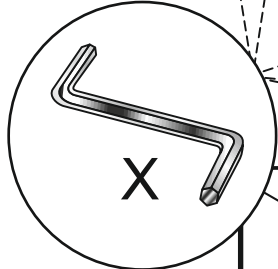
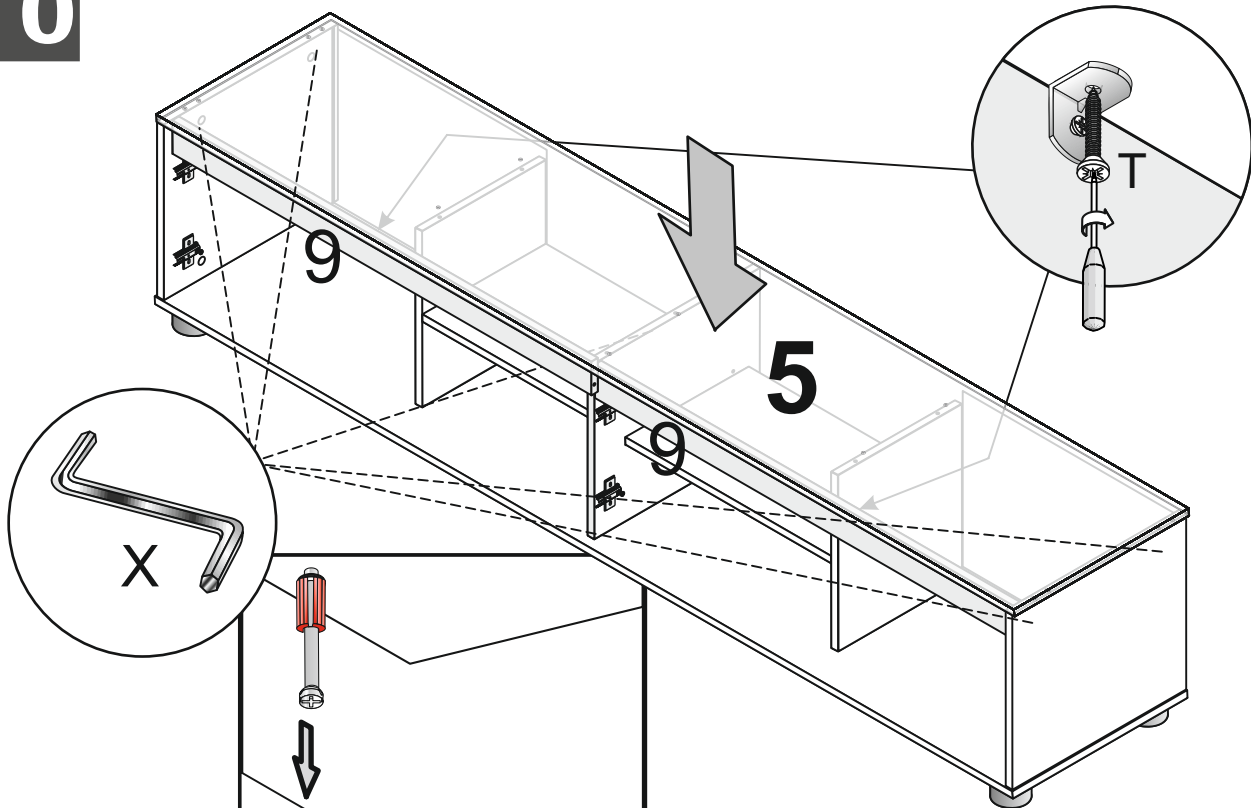

10

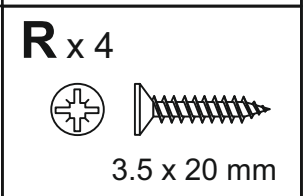
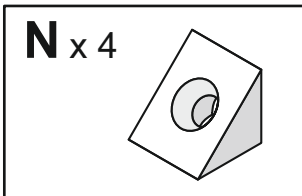
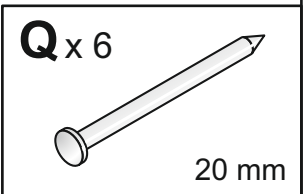
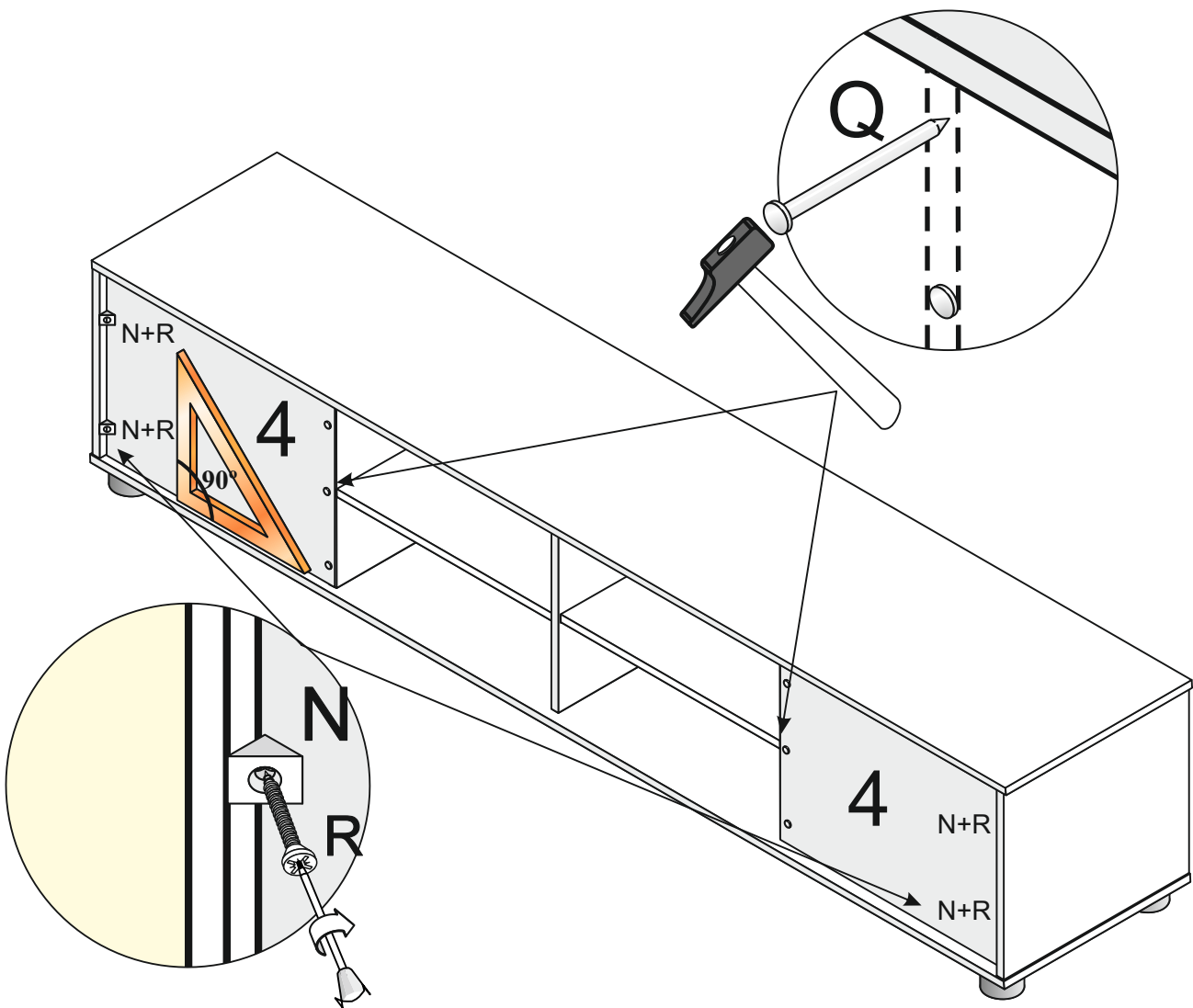
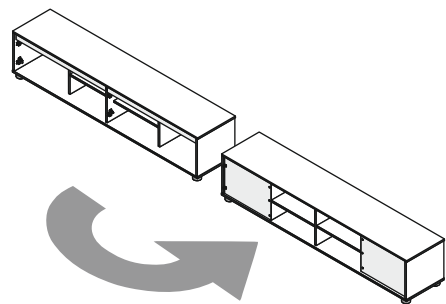

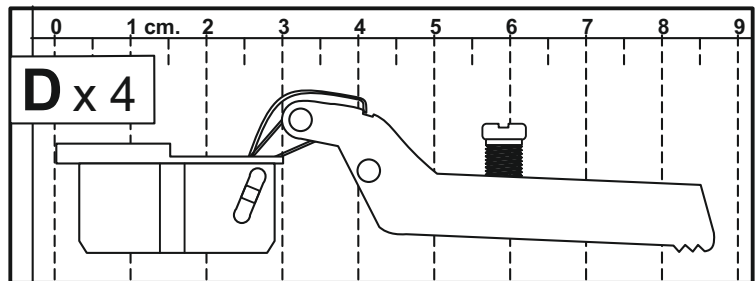
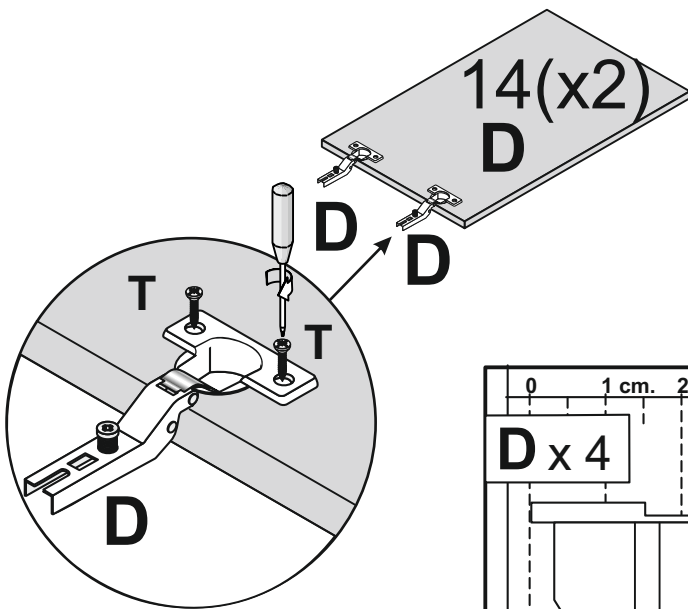
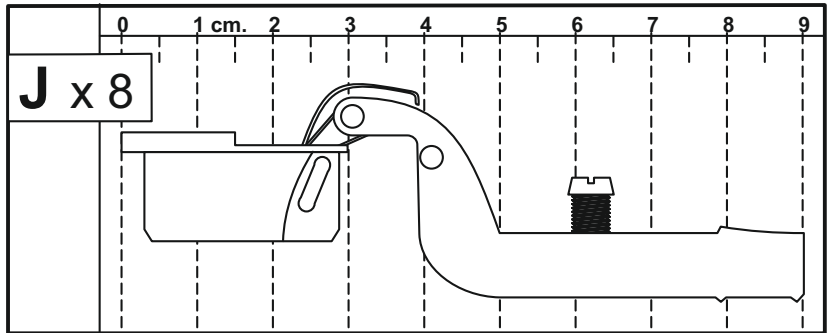
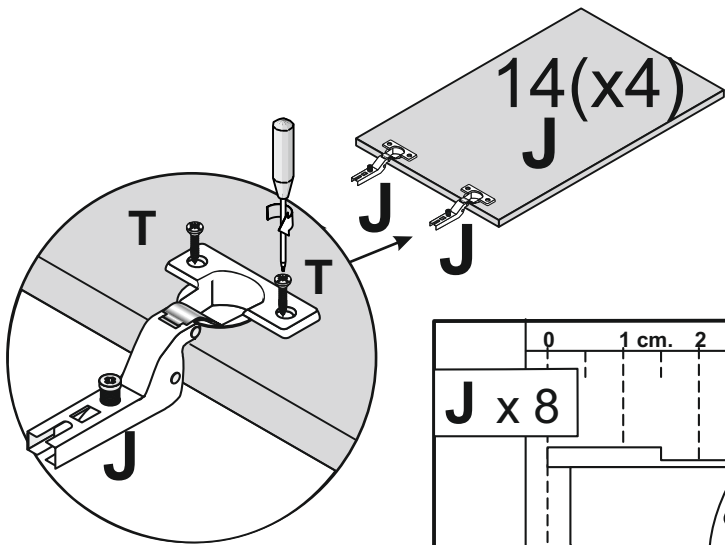





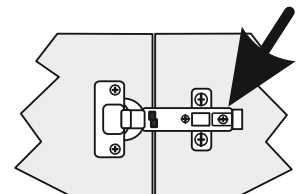
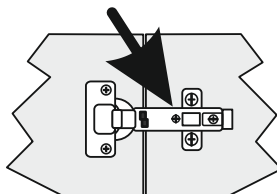
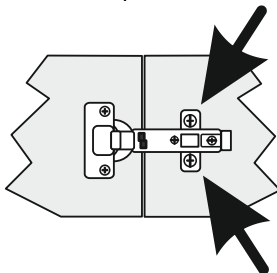
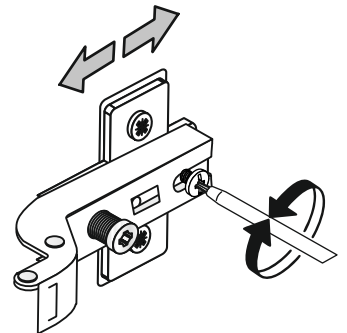
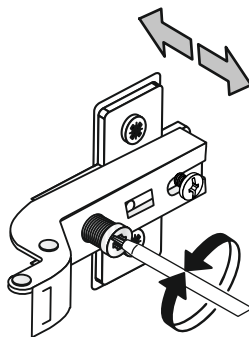
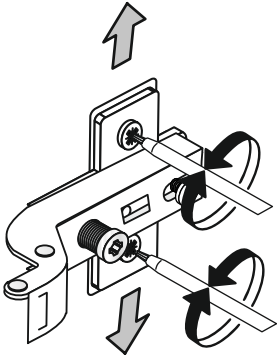
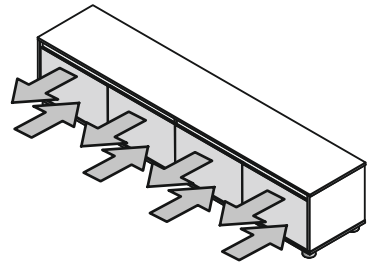
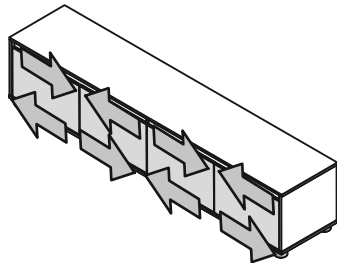
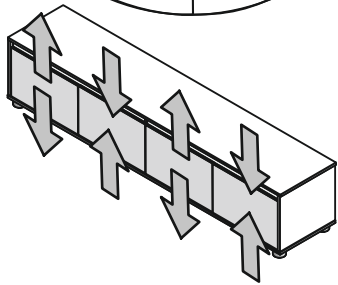
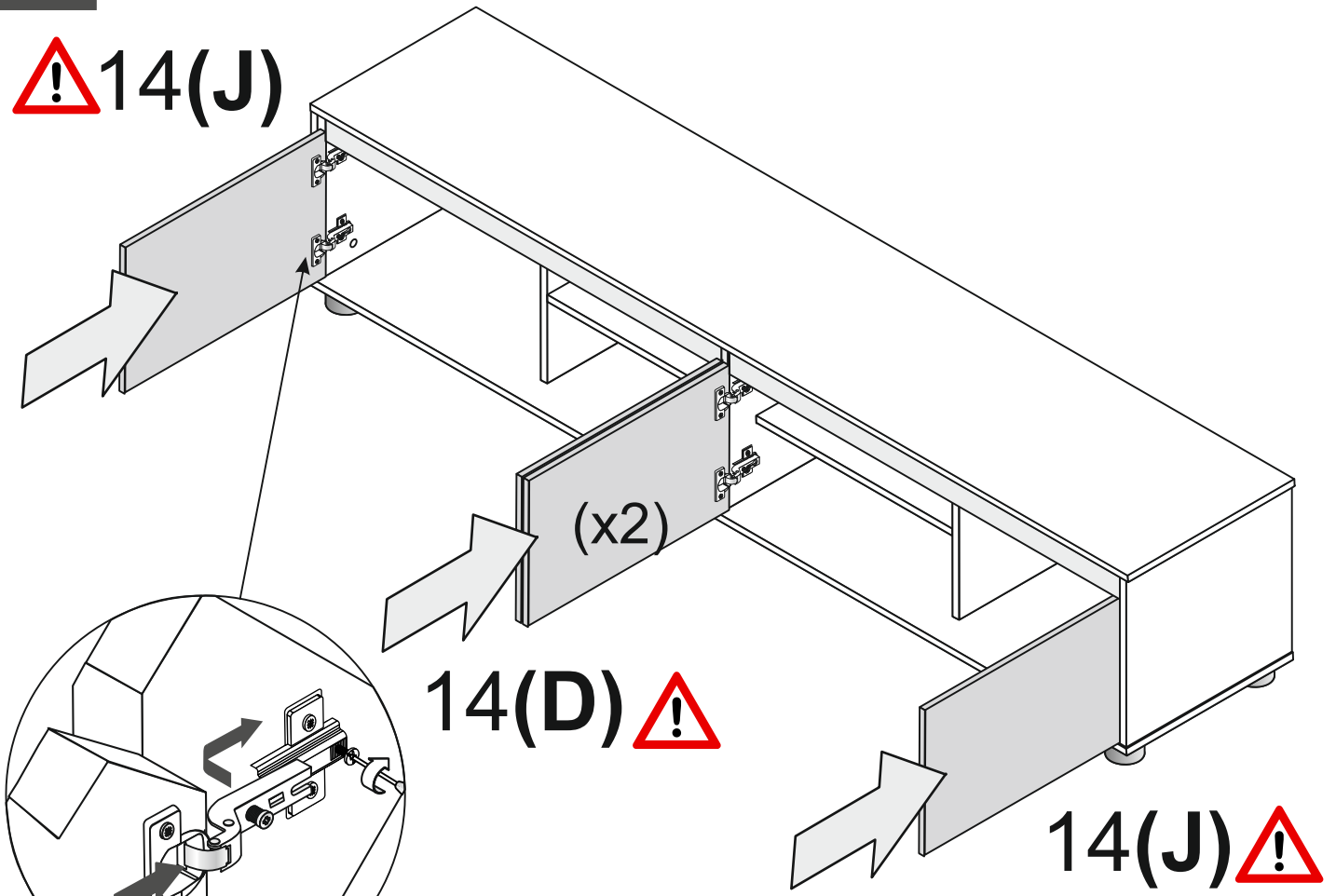

T x 24

4 x 16 mm

13

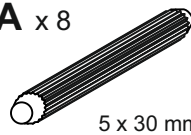
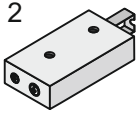
⚠ 14(J)

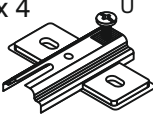

14

- A x 8**
 5 x 30 mm
- H x 2**

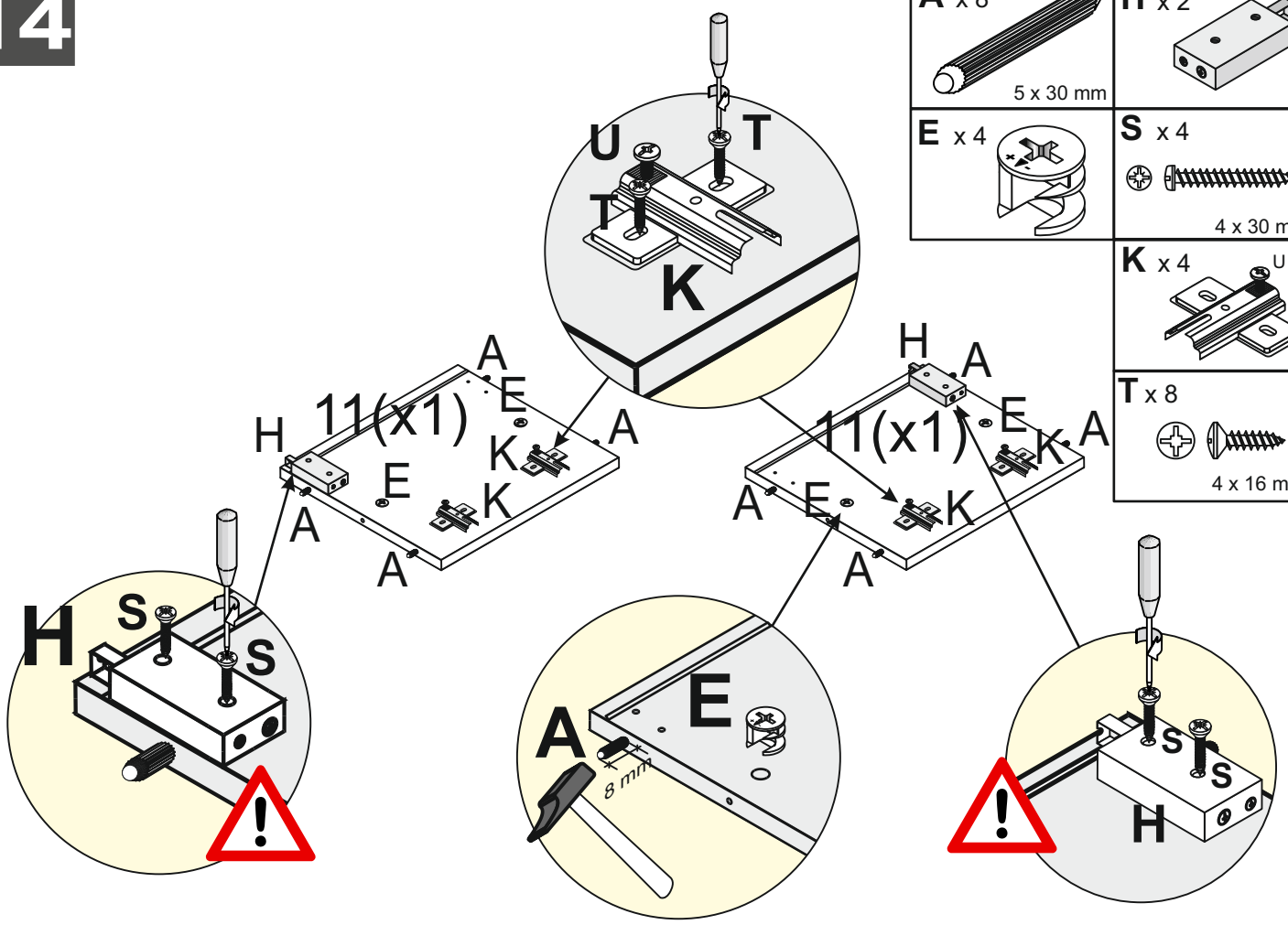
- E x 4**

- S x 4**
 4 x 30 mm
- K x 4**

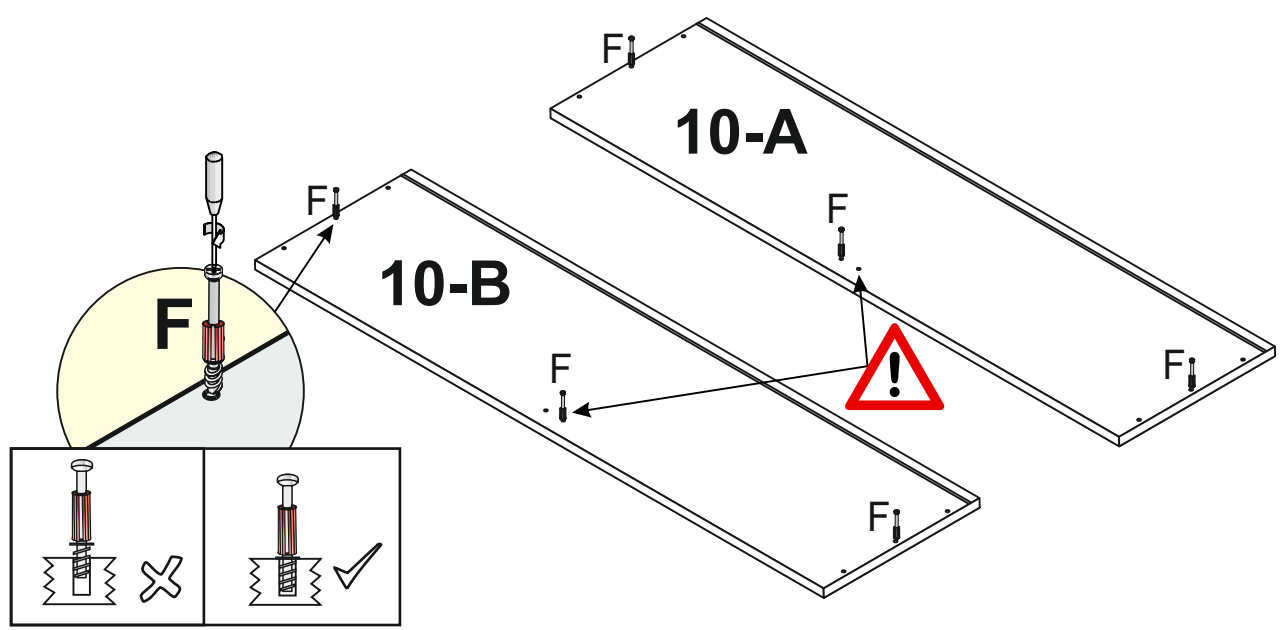
- T x 8**
 4 x 16 mm

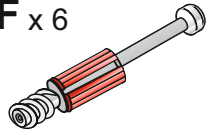

15



- F x 6**

16

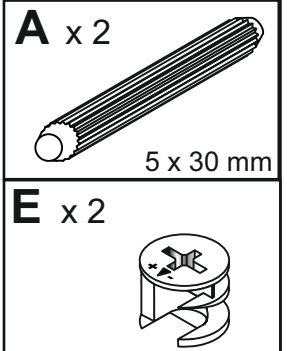
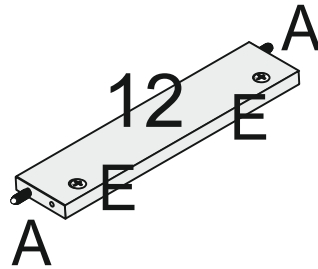
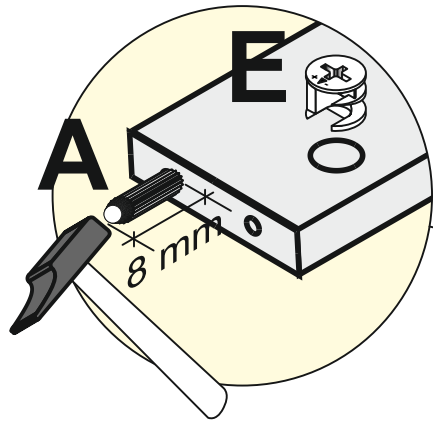

17

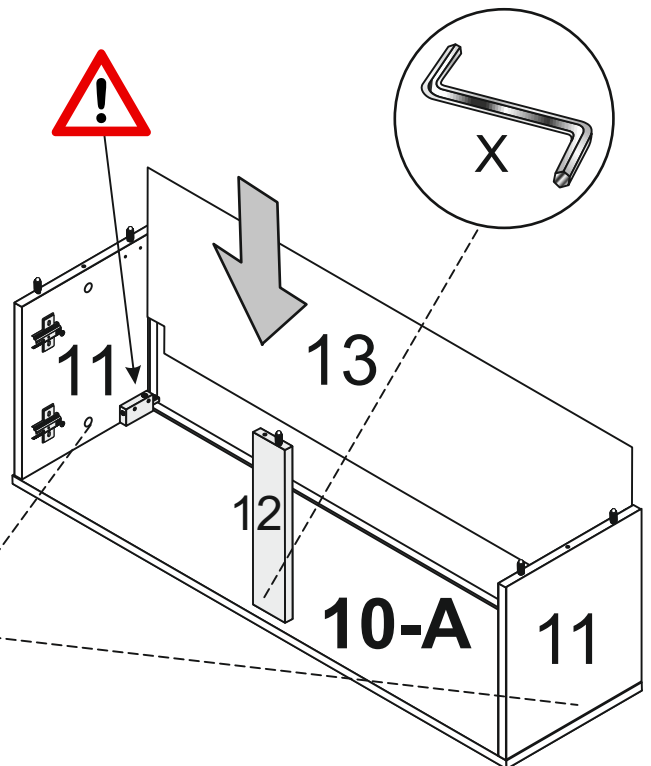
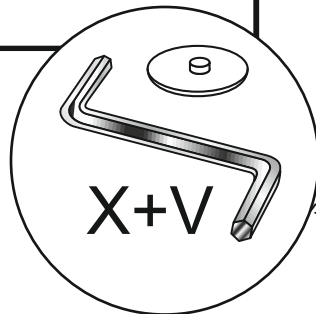
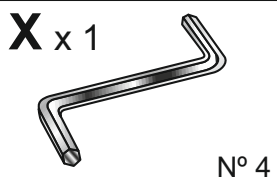
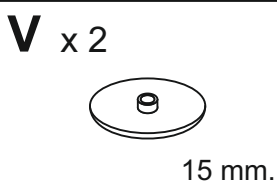
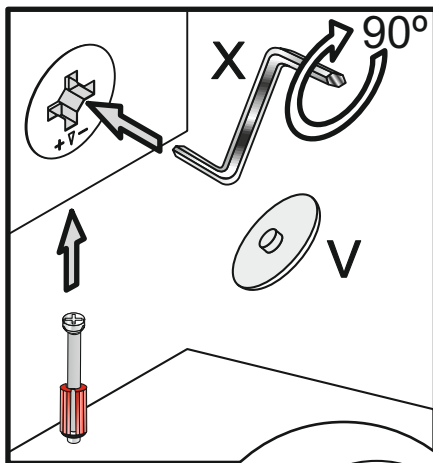

18

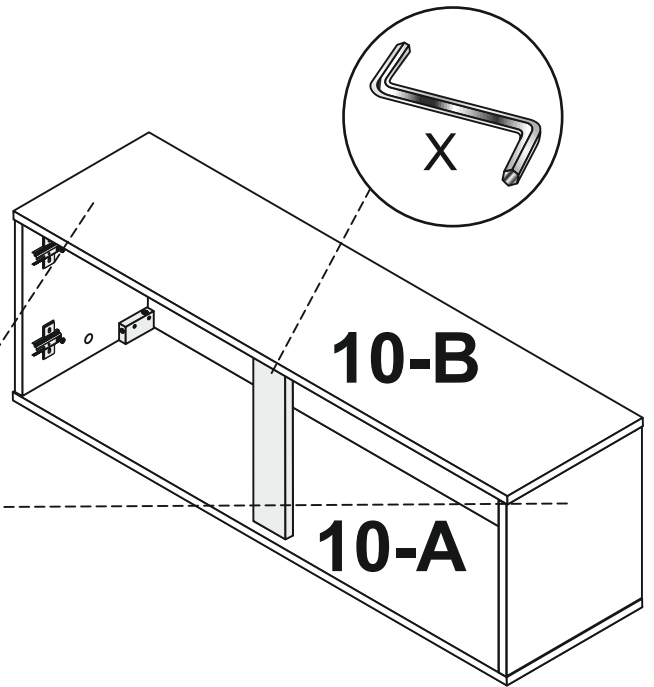
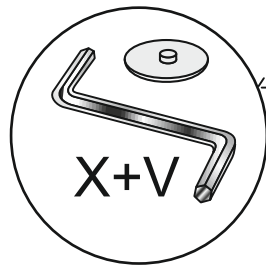
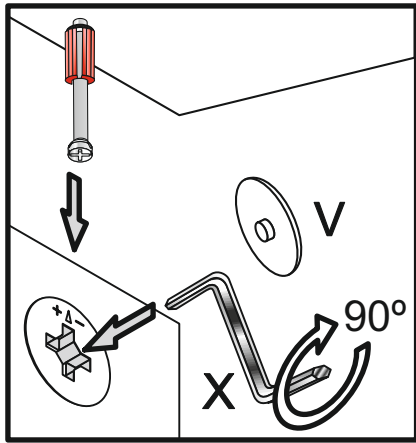

V x 2

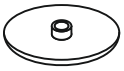

15 mm.

X x 1

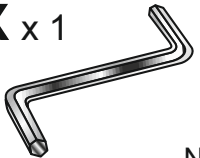

N° 4

19

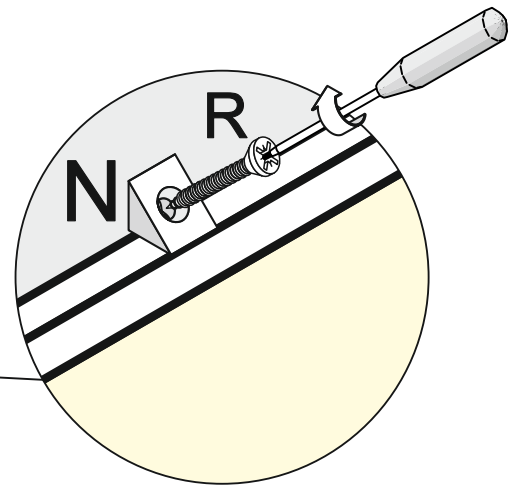
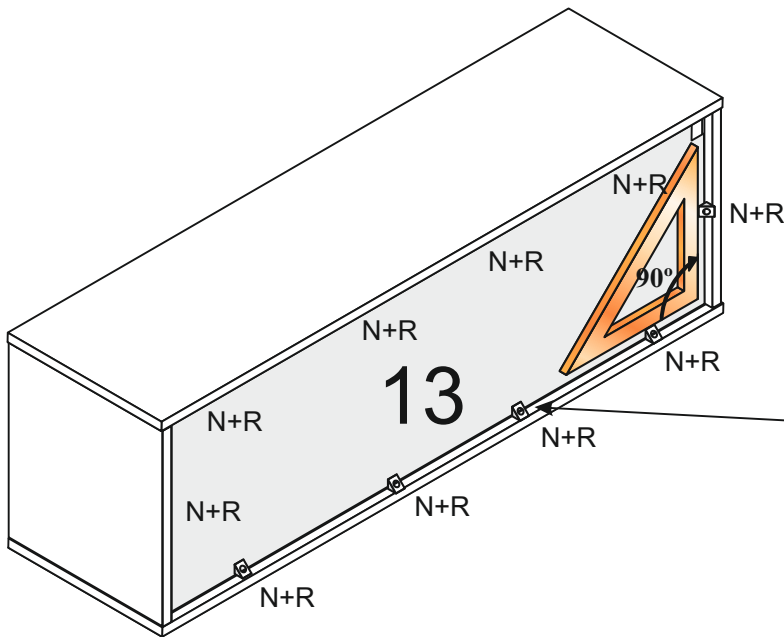

R x 10



3.5 x 20 mm

N x 10

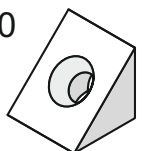

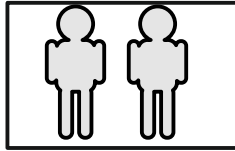
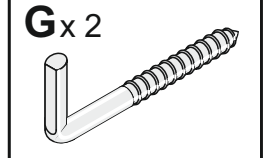
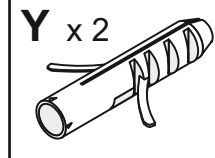

- ES** · USE HERRAJES ADECUADOS PARA EL MATERIAL DE LAS PAREDES DE SU CASA
- EN** · USE FIXING DEVICES SUITABLE FOR THE WALLS IN YOUR HOME
- FR** · UTILISEZ DES FIXATIONS ADAPTÉES AU MATÉRIAU DU MUR
- PT** · UTILIZE FERRAGENS ADEQUADAS ÀS PAREDES DA SUA CASA
- IT** · USA SISTEMI DI FISSAGGIO ADATTI ALLE PARETI DELLA TUA CASA
- DE** · BEFESTIGUNGSBESCHLÄGE BENUTZEN, DIE FÜR DIE HEIMISCHEN WÄNDE GEEIGNET SIND
- GR** · ΧΡΗΣΙΜΟΠΟΙΗΣΤΕ ΕΞΑΡΤΗΜΑΤΑ ΣΤΕΡΕΩΣΗΣ ΚΑΤΑΛΛΗΛΑ ΓΙΑ ΤΟΥΣ ΤΟΙΧΟΥΣ ΤΟΥ ΣΠΙΤΙΟΥ ΣΑΣ

1°

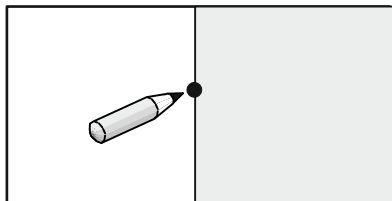

2°

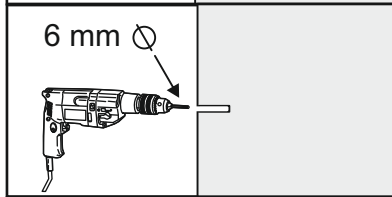

3°

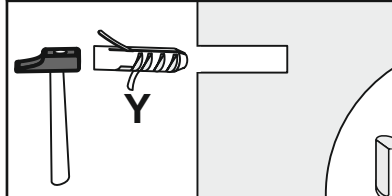

4°

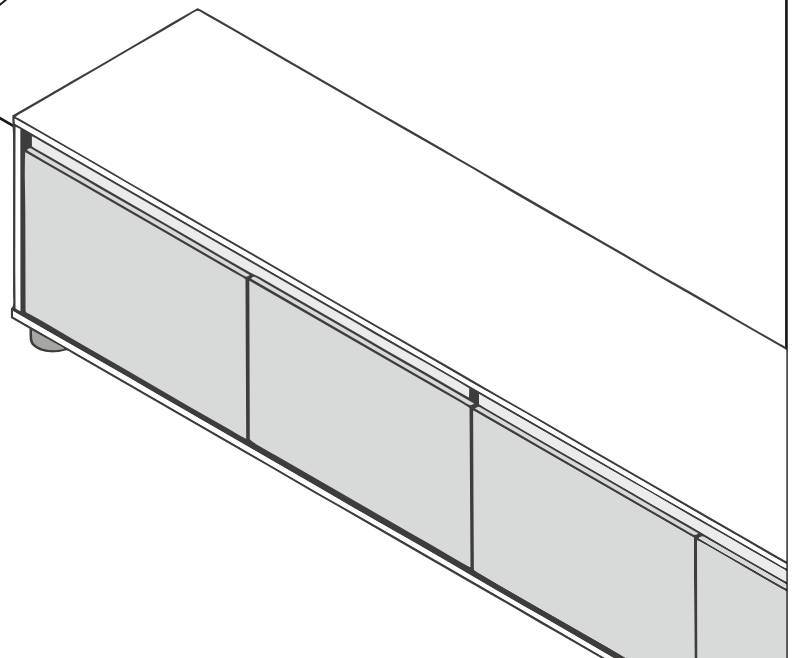
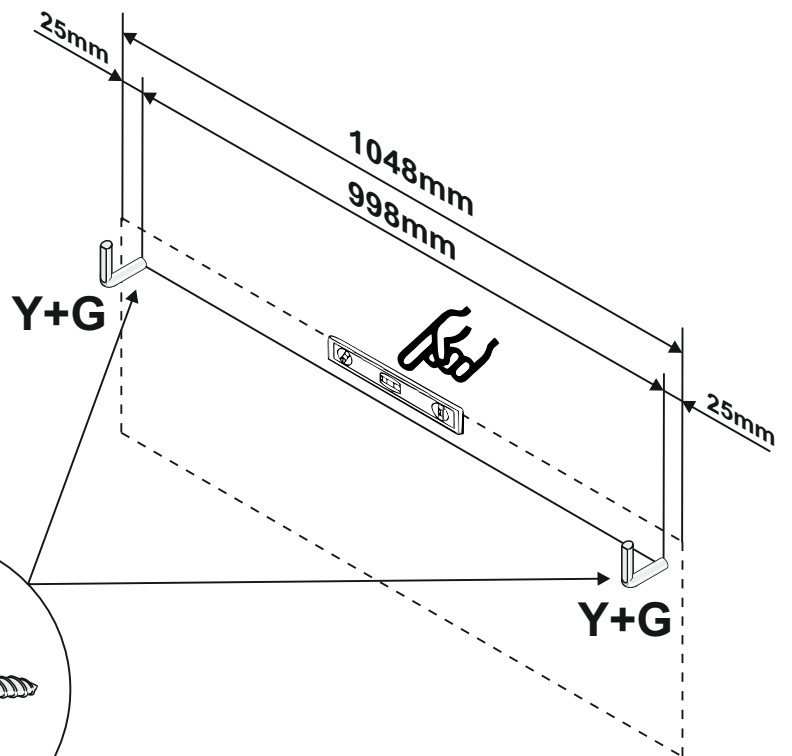
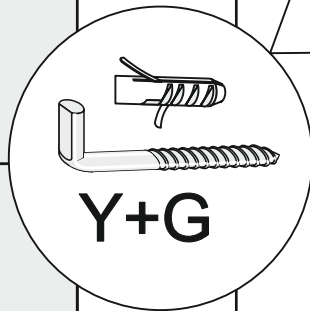
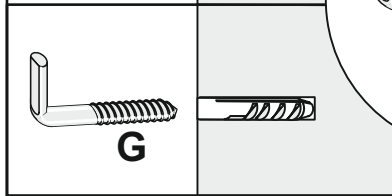

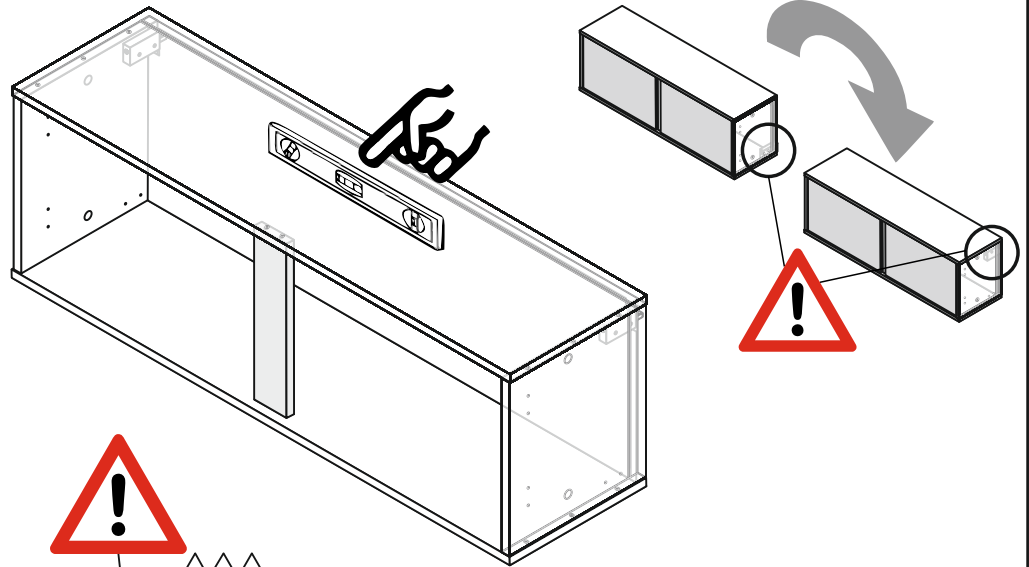

5°

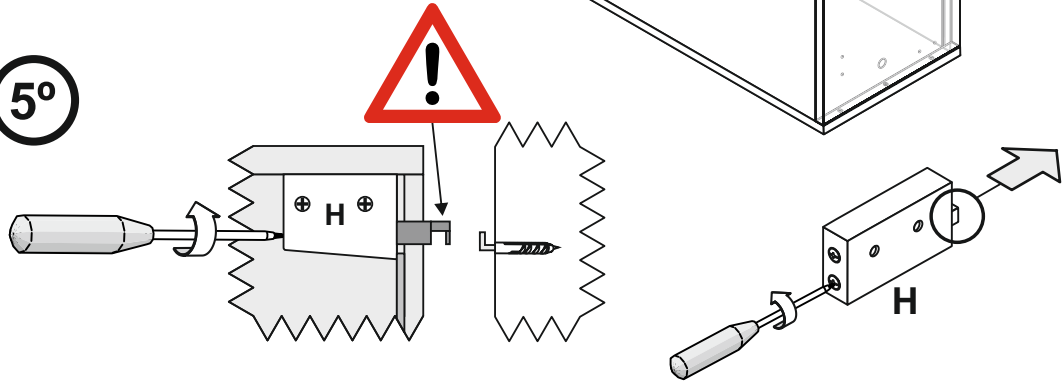

6°

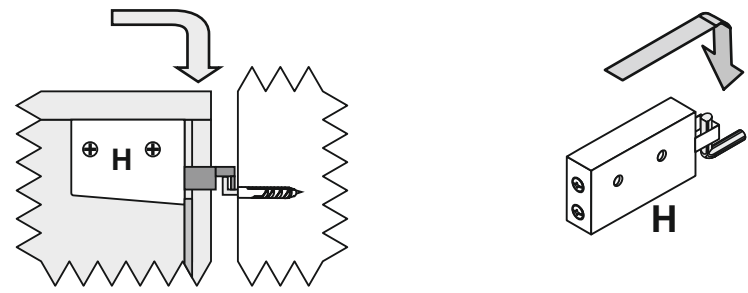

7°

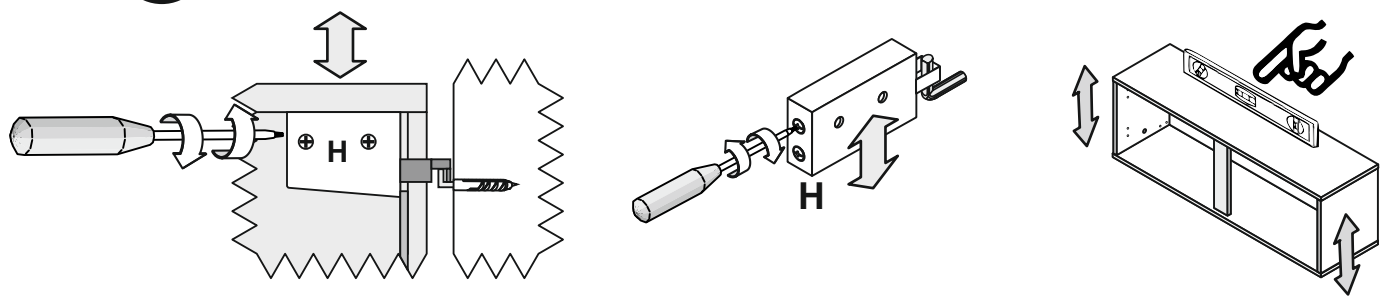

8°

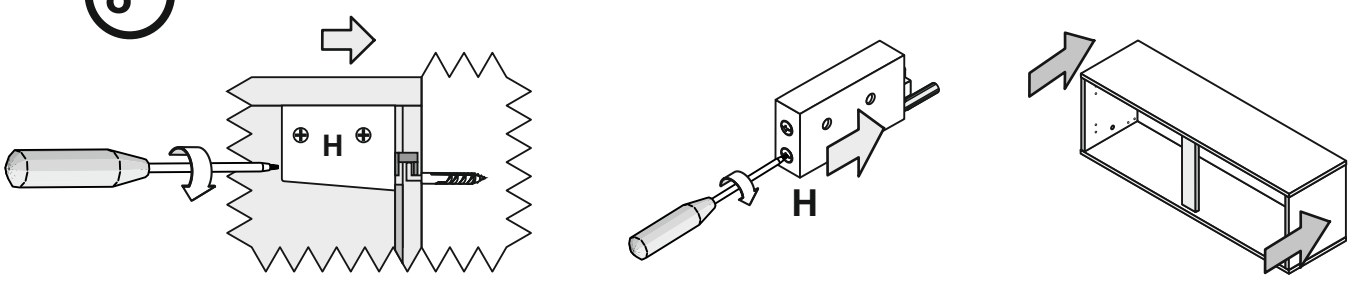

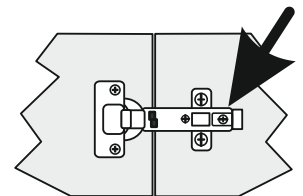
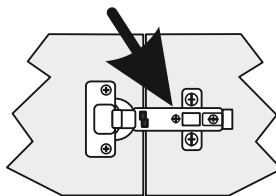
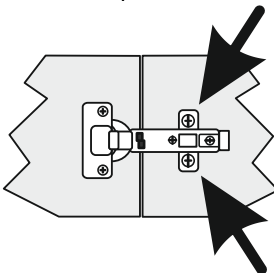
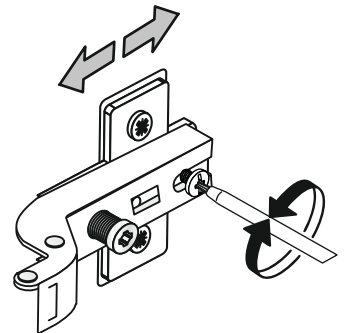
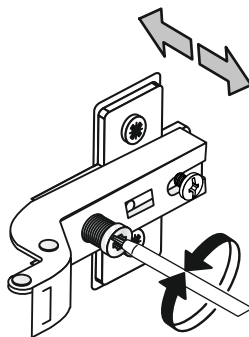
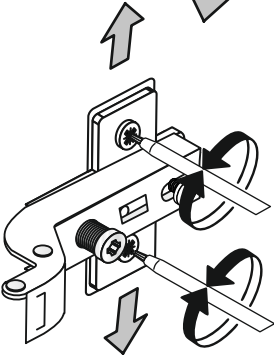
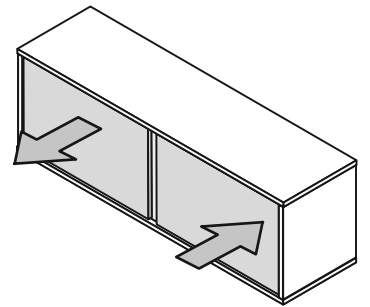
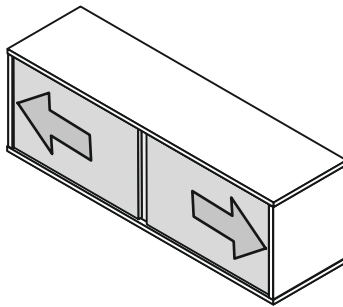
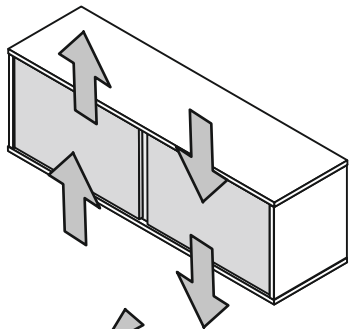
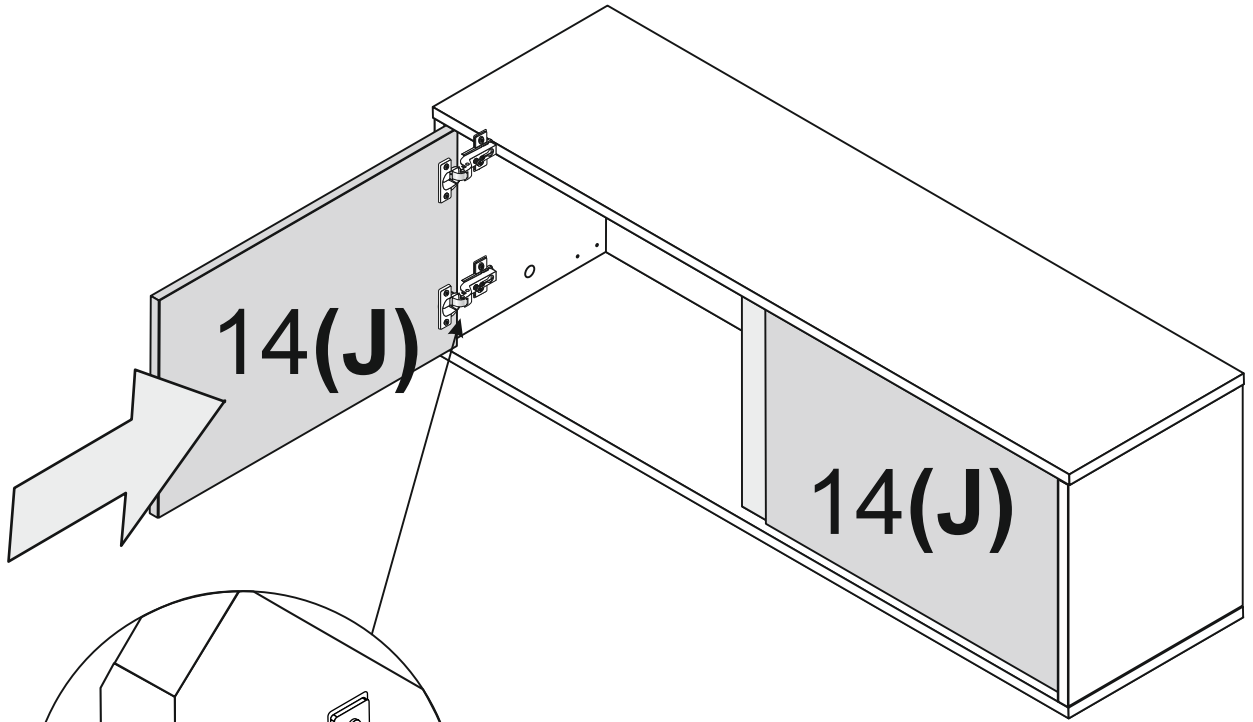

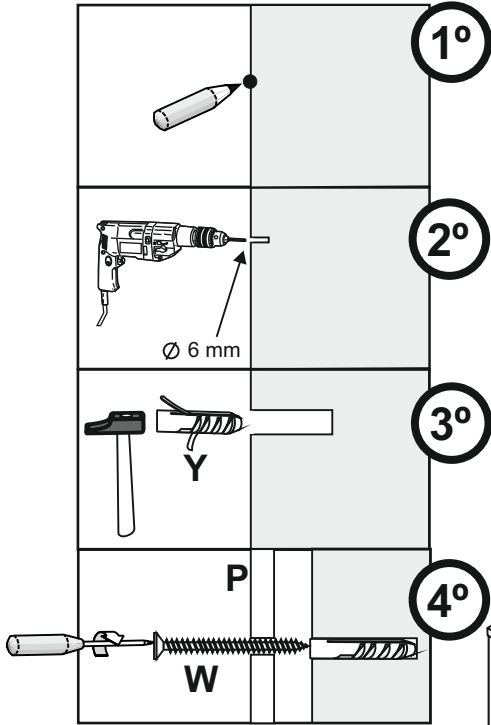
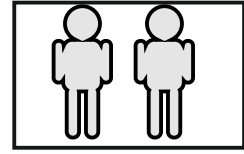

- ES** · USE HERRAJES ADECUADOS PARA EL MATERIAL DE LAS PAREDES DE SU CASA
- EN** · USE FIXING DEVICES SUITABLE FOR THE WALLS IN YOUR HOME
- FR** · UTILISEZ DES FIXATIONS ADAPTÉES AU MATÉRIAU DU MUR
- PT** · UTILIZE FERRAGENS ADEQUADAS ÀS PAREDES DA SUA CASA
- IT** · USA SISTEMI DI FISSAGGIO ADATTI ALLE PARETI DELLA TUA CASA
- DE** · BEFESTIGUNGSBESCHLÄGE BENUTZEN, DIE FÜR DIE HEIMISCHEN WÄNDE GEEIGNET SIND
- GR** · ΧΡΗΣΙΜΟΠΟΙΗΣΤΕ ΕΞΑΡΤΗΜΑΤΑ ΣΤΕΡΕΩΣΗΣ ΚΑΤΑΛΛΗΛΑ ΓΙΑ ΤΟΥΣ ΤΟΙΧΟΥΣ ΤΟΥ ΣΠΙΤΙΟΥ ΣΑΣ

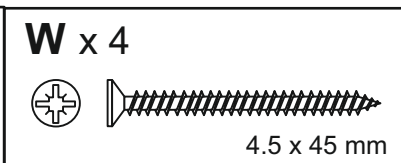
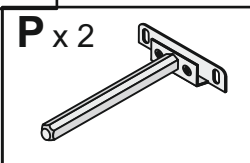
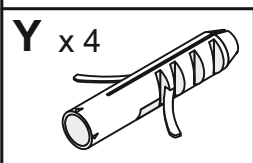
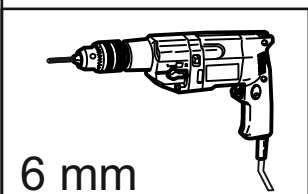
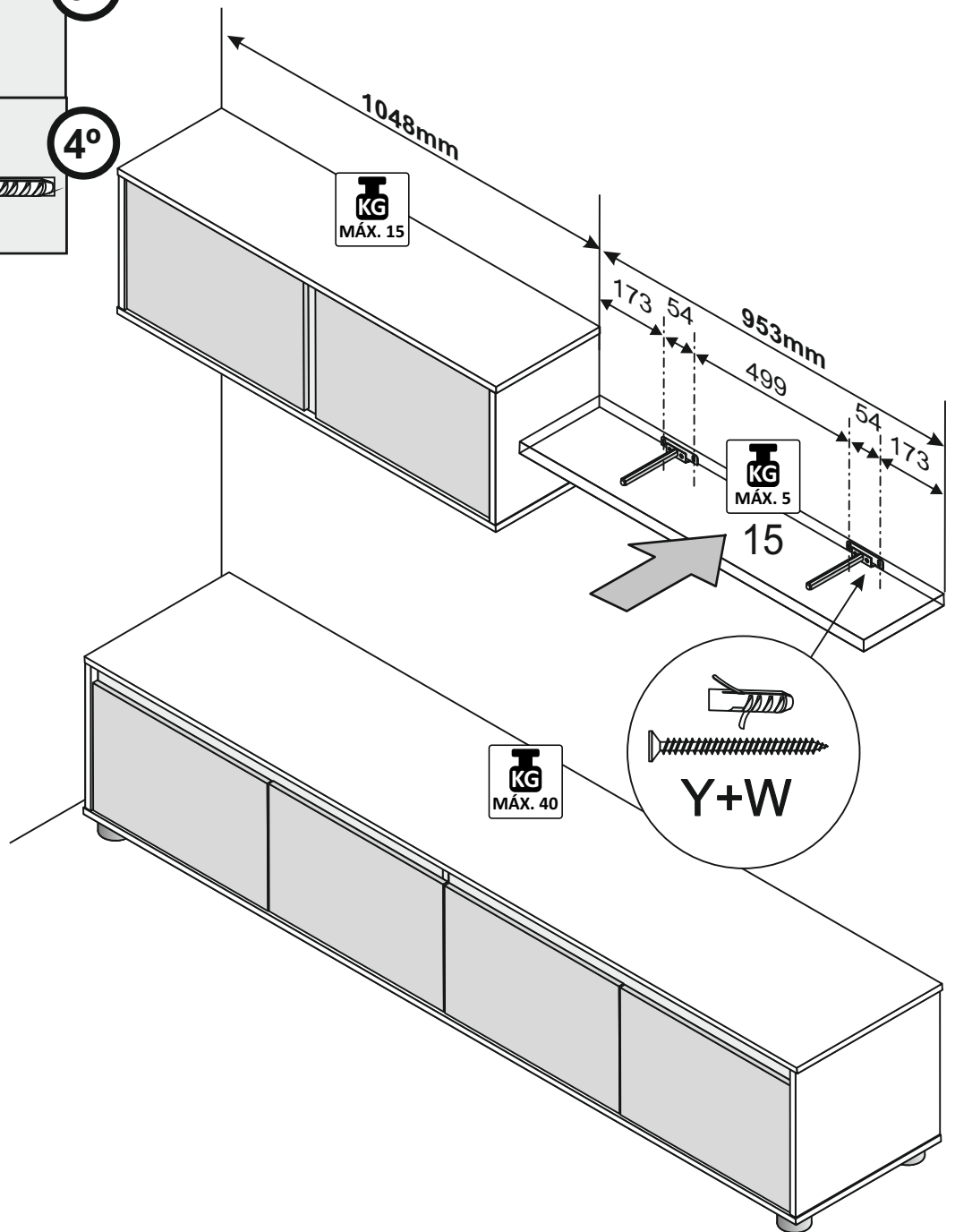

ES

INFORMACIÓN IMPORTANTE SOBRE EL MONTAJE DE LOS MUEBLES EN LA PARED

- Una vez montado según las instrucciones de montaje, el mueble está listo para montar en la pared. Un montaje de pared incorrecto puede ocasionar la caída del mueble y, por tanto, graves daños materiales y/o personales. Forés Diseño no se hace responsable de daños personales o materiales ocasionados por un montaje de pared incorrecto.
- La pared debe tener la resistencia necesaria para el montaje de los muebles en pared, no se debe realizar el montaje en paredes sin primero asegurarse de que la pared tenga la resistencia requerida o haya sido reforzada adecuadamente. Utilice herrajes adecuados para el material de las paredes de su casa. Póngase en contacto con su ferretero local que le asesorará en la elección del sistema de tornillos correcto para el tipo de material de la pared.

EN

IMPORTANT INFORMATION ABOUT THE ASSEMBLING OF WALL HUNG UNITS

- Once the furniture has been assembled according to the instructions, it's ready to get wall hanged. The furniture can drop down if it hasn't been mounted correctly what can also cause serious material and/ or personal damage. Forés Diseño does not assume the responsibility for personal or material damages caused by an incorrect mounting of the wall hung unit.
- Ensure that the wall is resistant enough to carry the weight of the furniture or has been reinforced suitably. Use appropriate hardware for the material of the walls of your house. Contact your local ironmonger who will advise you in choosing the right screw system for the type of material of your wall.

FR

INFORMATIONS IMPORTANTES CONCERNANT LE MONTAGE MURAL DU MOBILIER

- Une fois le meuble monté, après avoir suivi les instructions de montage, il s'agit de fixer le meuble au mur en toute sécurité. En cas de montage mural incorrect, le meuble risque de basculer et de tomber par terre; entraînant ainsi de graves dommages matériels et/ou blessures. Forés Diseño décline toute responsabilité en cas de blessures ou de dommages matériels pour un accrochage mural incorrect.
- Le mur doit avoir la résistance nécessaire pour la fixation murale. Avant de fixer les meubles au mur il faut impérativement vérifier que le mur possède la résistance requise ou qu'il a été suffisamment renforcé. Le choix de la visserie à utiliser pour la fixation murale utilisée dépend de votre type de mur. Utilisez des fixations adaptées. Contactez votre quincaillier local de confiance pour sélectionner la visserie à utiliser pour la fixation murale.

PT

INFORMAÇÕES IMPORTANTES SOBRE A MONTAGEM DOS MOVÉIS NA PAREDE

- Uma vez montado de acordo com as instruções de montagem, o mobiliário está pronto para ser montado na parede. A montagem incorreta na parede pode causar a queda do mobiliário e, portanto, sérios danos materiais e / ou pessoais. Forés Diseño não se faz responsável por danos pessoais ou materiais causados por uma montagem incorreta na parede.
- A parede deve ter a resistência necessária para a montagem dos móveis na parede, não deve ser montada nas paredes sem primeiro garantir que a parede tem a força necessária ou foi adequadamente reforçada. Use o hardware adequado para o material das paredes da sua casa. Entre em contato com o ferrageiro local, que irá aconselhá-lo a escolher o sistema de parafuso direito para o tipo de material de parede.

IT

INFORMAZIONE IMPORTANTE RIGUARDO IL FISSAGGIO ALLA PARETE DEL MOBILE

- Secondo le istruzioni, una volta montato il mobile, sarà pronto per essere fissato alla parete. Un fissaggio alla parete non corretto può ocasionare la caduta del mobile e conseguenti gravi danni materiali e/o a persone. Forés Diseño non si assume la responsabilità di possibili danni personali o materiali causati da un incorretto fissaggio del mobile alla parete.
- La parete deve avere la resistenza necessaria per sopportare il peso del mobile, non si deve realizzare il fissaggio in una parete senza anteriormente verificare la reale capacità di carico, o se non si è adeguatamente rinforzata per sostenere il peso del mobile. Per il fissaggio, utilizza la ferramenta più adatta al materiale della parete. Nel caso di dubbi, chiedi consiglio al Suo negozio ferramenta di fiducia, sulla scelta delle viti e tasselli più adatti al tipo di materiale della parete.

DE

WICHTIGE INFORMATIONEN ZUR MONTAGE VON HÄNGEMÖBELN

- Nach der Montage gemäß der Montageanleitung sind die Möbel bereit für die Befestigung an der Wand. Eine falsche Befestigung kann zum Fall des Möbels führen, was schwerwiegende Material- und / oder Personenschäden zur Folge haben kann. Forés Diseño haftet nicht für Personen- oder Sachschäden, die durch eine inkorrekte Montage an der Wand verursacht wurden.
- Die Wand muss den notwendigen Widerstand für die Montage der Möbel an der Wand haben. Die Möbel sollten nicht an Wände montiert werden, ohne vorher sicherzustellen, dass die Wand die erforderliche Festigkeit hat oder ausreichend verstärkt wurde. Verwenden Sie geeignete Hardware für das Material der Wände Ihres Hauses. Wenden Sie sich an Ihren örtlichen Eisenwarenhändler, der Sie bei der Auswahl des richtigen Schraubensystems für Ihr Wandmaterial berät.

GR

ΣΗΜΑΝΤΙΚΕΣ ΠΛΗΡΟΦΟΡΙΕΣ ΣΧΕΤΙΚΑ ΜΕ ΤΗ ΣΤΗΡΙΞΗ ΕΠΙΠΛΩΝ ΣΕ ΤΟΙΧΟ

- Αφού συναρμολογήσετε αυτό το προϊόν σύμφωνα με τις οδηγίες συναρμολόγησης, μπορείτε να το στηρίξετε σε τοίχο. Η εσφαλμένη στήριξη μπορεί να οδηγήσει στην πτώση του προϊόντος από τον τοίχο, προκαλώντας σοβαρές υλικές ζημιές και/ή τραυματισμούς ατόμων. Η εταιρεία Forés Diseño δεν ευθύνεται για προσωπικές ή υλικές βλάβες που προκύπτουν από εσφαλμένη στήριξη.
- Ο τοίχος πρέπει να έχει την απαραίτητη αντίσταση για τη συναρμολόγηση των επίπλων στον τοίχο, η συναρμολόγηση στους τοίχους δεν πρέπει να πραγματοποιείται χωρίς να εξασφαλιστεί πρώτα ότι το τοίχωμα έχει την απαιτούμενη αντοχή ή έχει ενισχυθεί επαρκώς. Χρησιμοποιήστε κατάλληλο υλικό για το υλικό των τοίχων του σπιτιού σας. Επικοινωνήστε με κάποιον ειδικό για τη σωστή επιλογή των βιδών σε σχέση με το υλικό του τοίχου.

ES

RECOMENDACIONES PARA EL MONTAJE Y PARA EL USO

- Preparar las piezas que constituyen el mueble
- Reagrupar y contar el herraje
- Preparar las herramientas necesarias
- Prepara la zona de montaje
- Realizar el montaje sobre una moqueta para evitar rayar el mueble
- No forzar nunca los ensamblajes

- No colocar cerca de fuentes de calor
- No utilizar paños, trapos o productos de limpieza que puedan rayar la superficie del mueble
- Mueble apto para uso doméstico. Ubicación en el interior de la vivienda

IT

CONSEGLI PER L'INSTALLAZIONE E L'USO

- Preparate i componenti del mobile per il montaggio
- Ordinate e controllate la quantità della ferramenta
- Preparate gli attrezzi necessari
- Preparate un luogo idoneo al montaggio. Sistemate i componenti su un tappeto per non danneggiare le superfici
- Non forzate mai i componenti

- Non posizionate il mobile vicino a fonti di calore
- Non usate panni abrasivi né detergenti né solventi che possano danneggiare le superfici
- Questo prodotto è solo per uso domestico, non professionale. Non adatto per uso all'aperto

EN

RECOMMENDATIONS FOR FITTING AND FOR USE

- Prepare the pieces of furniture to make it up
- Group up and count the iron parts, screws... etc.
- Prepare the necessary tools
- Prepare the fitting place
- Do the fitting on a carpet so you don't damage the furniture
- Never force the fitting

- Do not put near to any sort of heat
- Do not use cloths or cleaning products that could damage the surface of the furniture
- Furniture suitable for domestic use, keep indoors

DE

MONTAGEHINWEISE UND GEBRAUCHSHINWEISE

- Sortieren und identifizieren Sie die Einzelteile
- Überprüfen Sie die Anzahl der einzelnen Beschlagteile
- Legen Sie das notwendige Werkzeug bereit
- Einen montagebereich freimachen
- Montieren Sie das Möbel auf einem ebenen, weichen, sauberen Untergrund
- Niemals die verbindungen zu stark anziehen

- Nicht neben Wärmequellen platzieren.
- Für die Reinigung verwenden Sie bitte ein weiches Tuch und keinesfalls scharfe oder ätzende Reinigungsmittel.
- Das Möbel ist ausschließlich für den Gebrauch im Haus geeignet.

FR

CONSEILS DE MONTAGE ET POUR L'USAGE

- Identifier les différents panneaux
- Regrouper et compter la quincaillerie
- Munissez-vous de l'outillage nécessaire
- Amenagez-vous une zone de montage. La moquette ou une couverture protégera des rayures
- Ne jamais forcer le montage

- Ne pas placer près des sources de chaleur
- N'utiliser pas de chiffons ou des produits de nettoyage qui puissent rayer la superficie du meuble
- Meuble apte pour l'usage domestique, on peut le placer à l'intérieur de la maison

PT

AVISO PARA MONTAGEM E PARA USO

- Preparar as peças que compõem o móvel
- Reagrupar e contar as ferragens
- Preparar as ferramentas necessárias
- Prepara o local para a montagem
- Efectuar a montagem sobre uma alcatifa para evitar arranhar o móvel
- Não forçar nunca a ensambladura

- Não colocar perto de fontes de calor
- Não utilizar panos, trapos ou produtos de limpeza que possam riscar a superfície do móvel
- Móvel apto para o uso doméstico. Colocação no interior da vivenda

GR

ΣΥΜΒΟΥΛΕΣ ΣΥΝΑΡΜΟΛΟΓΗΣΗΣ ΚΑΙ ΧΡΗΣΗΣ

- Προετοιμάστε τα μέρη του επίπλου
- Ομαδοποιήστε και μετρήστε τα μικρά μέρη (βίδες, μεντεσέδες...)
- Προετοιμάστε τα εργαλεία που θα χρειαστείτε
- Προετοιμάστε το χώρο συναρμολόγησης
- Μία μοκέτα θα προφύλασσε από γρατζουνιές
- Μη ασκείτε πίεση στην εφαρμογή

- Μη τοποθετείτε κοντά σε πηγή θερμότητας
- Μη χρησιμοποιείτε πανιά και καθαριστικά που μπορούν να καταστρέψουν την επιφάνεια
- Το έπιπλο έχει κατασκευαστεί για οικιακή χρήση, τοποθετήστε το στο εσωτερικό της οικίας

GARANTÍA - GUARANTEE - GARANTIE - GARANTIA - GARANZIA - GARANTIE - GARANTISI

ES · Fabricado en U.E. por FORES DISEÑO S.L. C.I.F: B-12313003 - Ctra.Nac.232; Km 11,1 C.P. 12320 - Sant Jordi (Castellón) SPAIN - el cual garantiza este producto por un periodo de **2 años** a partir de la fecha de compra, contra todo defecto de fabricación.

· Si se encuentra alguna dificultad a la hora del montaje o existe algún defecto en el mueble, puede contactar con nosotros al **964 46 52 22** o por e-mail: **postventa@fores.es** donde gustosamente atenderemos todas sus consultas. HORARIO: de lunes a viernes de 9h a 14h y de 15h a 18h.

· Esta garantía no ampara los defectos producidos por un mal montaje, utilización indebida o mal uso del mueble.

· Es imprescindible conservar el **ticket** de compra y facilitar el **Nº de Control de Calidad (Q.C.)** para cualquier consulta o reclamación.

EN · Manufactured in Spain by FORES DISEÑO S.L. CIF B-12313003-ctra Nac 232 km 11.1 C.P.12320-Sant Jordi, (Castellón) SPAIN - Guarantee of **2 years** from date of purchase against any fault of production.

· If a difficulty when assembly or a fault in the product is found you can contact us at **(+34) 964 46 52 22** or by email: **postventa@fores.es** where we will be pleased to help you. TIMETABLE: Monday until Friday 9-14h / 15-18h.

· The Guarantee does not cover the faults produced by an incorrect assembly or misuse of the furniture.

· Indispensable to keep the purchase **ticket** and facilitate the **Nº of Quality Control (Q.C.)** for any consult or claim.

FR · Fabriqué en UE par FORES DISEÑO S.L. CIF B-12313003 - Ctra Nac 232; Km 11,1 CP12320 - Sant Jordi (Castellón) Espagne - Celui ci garantie ce produit pour une période de **2 ans** à partir de la date d'achat, contre tout défaut de fabrication.

· Si vous rencontrez une quelconque difficulté à l'heure du montage ou si il y a un défaut sur le meuble, vous pouvez nous contacter par téléphone au **(+34) 964 46 52 22** ou bien par e-mail à **postventa@fores.es** où nous aurons le plaisir de vous accueillir pour toutes demandes. Nos HORAIRES sont du lundi au vendredi de 9H00 à 14H00 et de 15H00 à 18H00.

· Cette garantie ne couvre pas les défauts résultants d'un mauvais montage, d'une utilisation indue ou d'un mauvais usage du produit.

· Il est indispensable de garder le **ticket** ou facture d'achat et de communiquer le **Numéro de Control Qualité (Q.C.)** pour une quelconque demande ou réclamation.

PT · Fabricado U.E. por FORES DISEÑO S.L. C.I.F: B-12313003 - Ctra.Nac.232; 11,1 km C.P. 12320 - Sant Jordi (Castellón) ESPANHA - que garante este produto por um período de **2 anos** a partir da data de compra; contra defeitos de fabricação.

· Se você encontrar qualquer dificuldade na montagem ou se houver qualquer defeito no armário, você pode contactar-nos pelos seguintes meios: **(+34) 964 46 52 22** ou por e-mail: **postventa@fores.es** onde será recebido de bom grado para atenderder-mos todas as suas dúvidas. HORÁRIOS: Segunda a sexta-feira das 9h às 14h e 15h às 18h.

· Esta garantia não cobre defeitos causados pela montagem incorreta, uso indevido ou mau trato do produto.

· É essencial manter o **recibo** de compra e facilitar o **Nº Controle de Qualidade (Q.C.)** para quaisquer dúvidas ou reclamações.

IT · Prodotto in Spagna da: FORES DISEÑO S.L. CIF B-12313003-ctra Nac 232 km 11.1 C.P.12320-Sant Jordi, (Castellón) SPAIN. Garantisito **2 Anni** dalla data di acquisto contro ogni difetto di produzione.

· In caso di difficoltà nel montaggio o di mancanza di componenti potete chiamare il **(+34) 964 46 52 22** o inviare email a: **postventa@fores.es**

· Il servizio è attivo dal Lunedì al Venerdì ore 9:00-14:00 / 15:00-18:00 Saremo lieti di aiutarvi.

· La garanzia non copre difetti o danni dovuti a montaggio scorretto o ad uso improprio del prodotto.

· La garanzia è valida solo in presenza dello **sccontrino di acquisto** e sarà più tempestiva se conservate il **nº di controllo qualità (Q.C.)** presente nella confezione.

DE · Hergestellt in Spanien von FORES DISEÑO S.L. CIF B-12313003-ctra Nac 232 km 11.1 CP12320-Sant Jordi (Castellón) SPANIEN - Garantie von **2 Jahren** ab Kaufdatum gegen jede störung der produktion.

· Wenn Sie irgendwelche schwierigkeiten bei der montage zu finden oder es irgendeinen defekt in dem schrank, können sie uns unter **(+34) 964 46 52 22** oder per email an: **postventa@fores.es**, wo wir gerne besuchen, um alle Ihre Fragen. ÖFFNUNGSZEITEN: Montag bis Freitag von 9h bis 14h und 15h bis 18h.

· Diese Garantie gilt nicht für Mängel, die durch unsachgemäße Installation, unsachgemäße Behandlung und Verwendung des Geräts verursacht werden.

· Unentbehrlich, um den **Kauf Ticket** behalten und erleichtern die Anzahl der **Qualitätskontrollzahl (Q.C.)** für alle zu konsultieren oder Anspruch.

GR · Κατασκευάζεται στην Ισπανία από CIF B-12313003-Ctra Nac 232 χλμ 11.1 CP12320-Sant Jordi, στην Ισπανία - Η εγγύηση ισχύει για **2 έτη** από την αρχική ημερομηνία αγοράς και καλύπτει ελαττωματικά υλικά ή ελαττωματική κατασκευή του προϊόντος.

· Σε περίπτωση δυσκολίας σας κατά την συναρμολόγηση ή πιθανής βλάβης στο προϊόν, μπορείτε να επικοινωνήσετε μαζί μας στο **(+34) 964 46 52 22** ή μέσω email: **postventa@fores.es**

· Η εγγύηση δεν καλύπτει τις βλάβες που προέρχονται από λάθη στην συναρμολόγηση ή την μη ορθολογική χρήση των επίπλων.

· Είναι απαραίτητο να κρατήσετε την **απόδειξη αγοράς** του προϊόντος και τον **αριθμό ποιοτικού ελέγχου (Q.C.)**, ώστε να διευκολύνετε οποιαδήποτε διαδικασία αίτησης ή συμβουλής χρειαστείτε.

Nº de Control de Calidad (Q.C.):
Nº of Quality Control (Q.C.):
Nº de Contrôle Qualité (Q.C.):
Nº de Controle de Qualidade (Q.C.):
Nº di Controllo qualità (Q.C.):
Qualitätskontrollzahl (Q.C.):
Ποιοτικός έλεγχος Αριθμός (Q.C.):



GUARDE ESTE NÚMERO
SAVE THIS NUMBER
SAUVEZ CE NUMÉRO
GUARDE ESTE NÚMERO
SALVA QUESTO NUMERO
SPEICHERN SIE DIESE NUMMER
ΦΥΛΑΞΤΕ ΑΥΤΟ ΤΟ ΑΡΙΘΜΟ

Q.C.
00000.18



**SALÓN TV - TV LIVING ROOM - SÉJOUR TV - MÓVEL PARA SALA -
TV SOGGIORNO - FERNSEHRAUM - ΕΠΙΠΛΑ ΓΙΑ ΤΟ ΣΑΛΟΝΙ**

